

MITSUBISHI SUMMIT

500kVA UPS DIRECT CABLE CONFIGURATION

CUSTOMER -
 PROJECT NUMBER -
 PROJECT LOCATION -

TABLE OF CONTENTS

SHEET NO.	TITLE
01	COVER SHEET
02	UPS ONE-LINE 1 DIAGRAM
03	UPS ONE-LINE 2 DIAGRAM
04	UPS ONE LINE 3 DIAGRAM
05	SINGLE LINE DIAGRAM
06	SYSTEM CONFIGURATION
07	EXTERNAL SIGNAL TERMINAL BLOCK
08	
09	
10	
11	
12	
13	
14	
15	

0 INITIAL RELEASE 7/20/16 GCU
1 REVISED DRAWING TO SHOW UPS 4/11/17 NR

DIM. IN: INCHES [MM]	SCALE: NTS	DRAFTER: G. JOHNSTON	DATE: 08/13/15
<small>PROPRIETARY THIS DOCUMENT IS PROPERTY OF MITSUBISHI ELECTRIC POWER PRODUCTS, INC. AND CONTAINS PROPRIETARY AND CONFIDENTIAL INFORMATION WHICH MUST NOT BE DUPLICATED, USED OR DISCLOSED OTHER THAN AS EXPRESSLY AUTHORIZED BY MITSUBISHI ELECTRICAL POWER PRODUCTS, INC.</small>		CHECKED: N. RIEMER	DATE: 08/13/15
REF. DWG. NO.:	APPROVED: K. BEAMER	ENGINEER: K. BEAMER	DATE: 08/13/15
FILE LOCATION:			



MITSUBISHI ELECTRIC

TITLE: SUMMIT 500KVA UPS DIRECT CABLE CONFIGURATION

DWG NO.: UD-100540 SHEET 1 OF 7 REV: 1

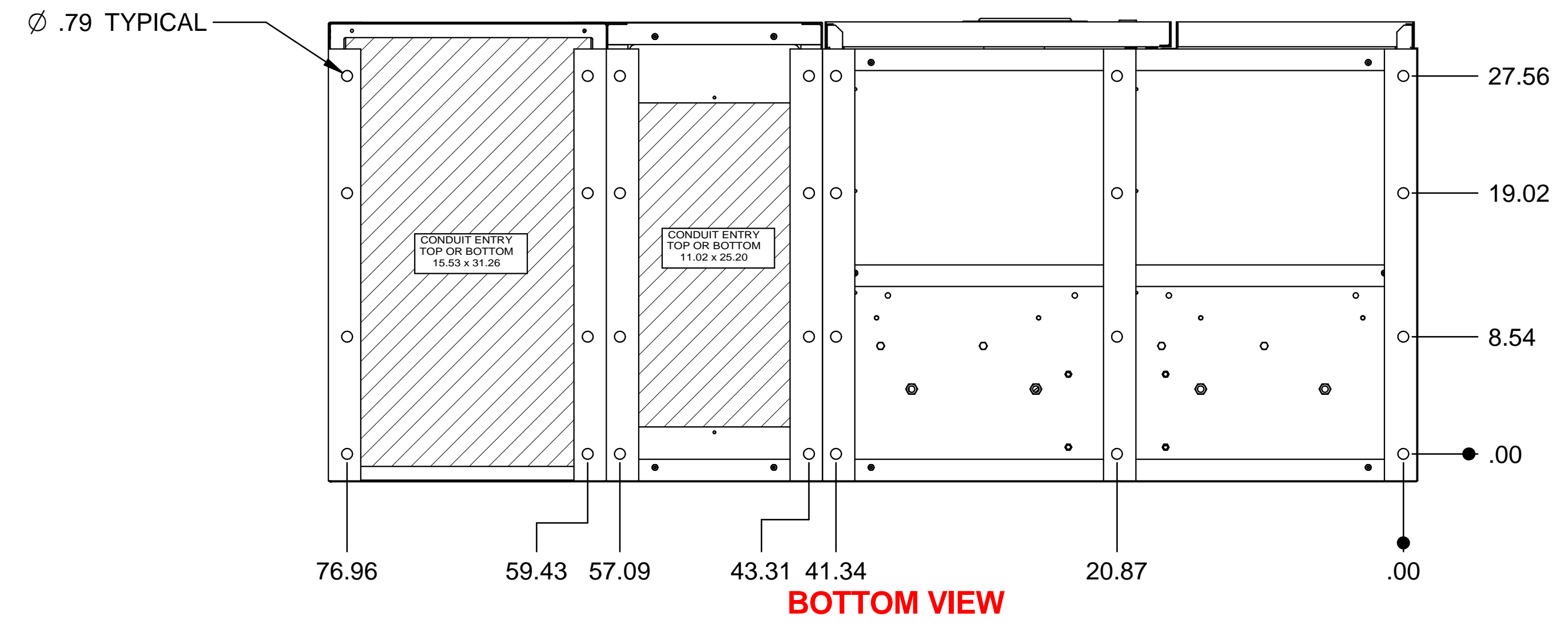

BOTTOM VIEW

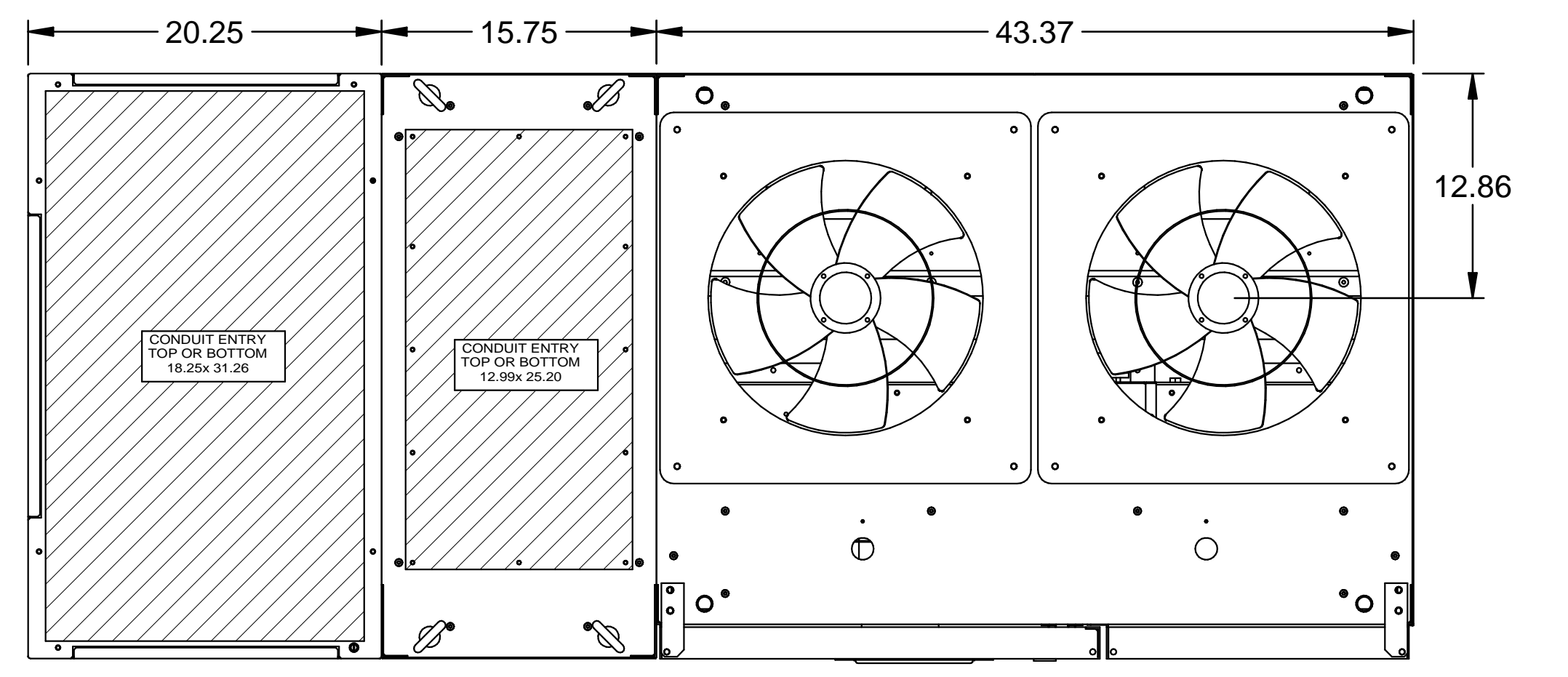

TOP VIEW

- NOTES**
1. FIELD CABLES AND TERMINATIONS BY OTHERS (AC INPUT,DC INPUT,BYPASS INPUT AND AC OUTPUT.)
 2. PHASE ROTATION CLOCKWISE A,B,C.
 3. 15.75" SIDECAR SHIPPED ATTACHED TO UPS.
 4. 20.25" SIDECAR SHIPPED SEPARATE.
 5. CABINET MUST MAINTAIN +/- 15° UPRIGHT.
 6. APPROXIMATE TOTAL WEIGHT 3,072LBS
 7. ALL PRODUCTS ARE UL LISTED
 8. 20.25" SIDECAR IS A WIREWAY

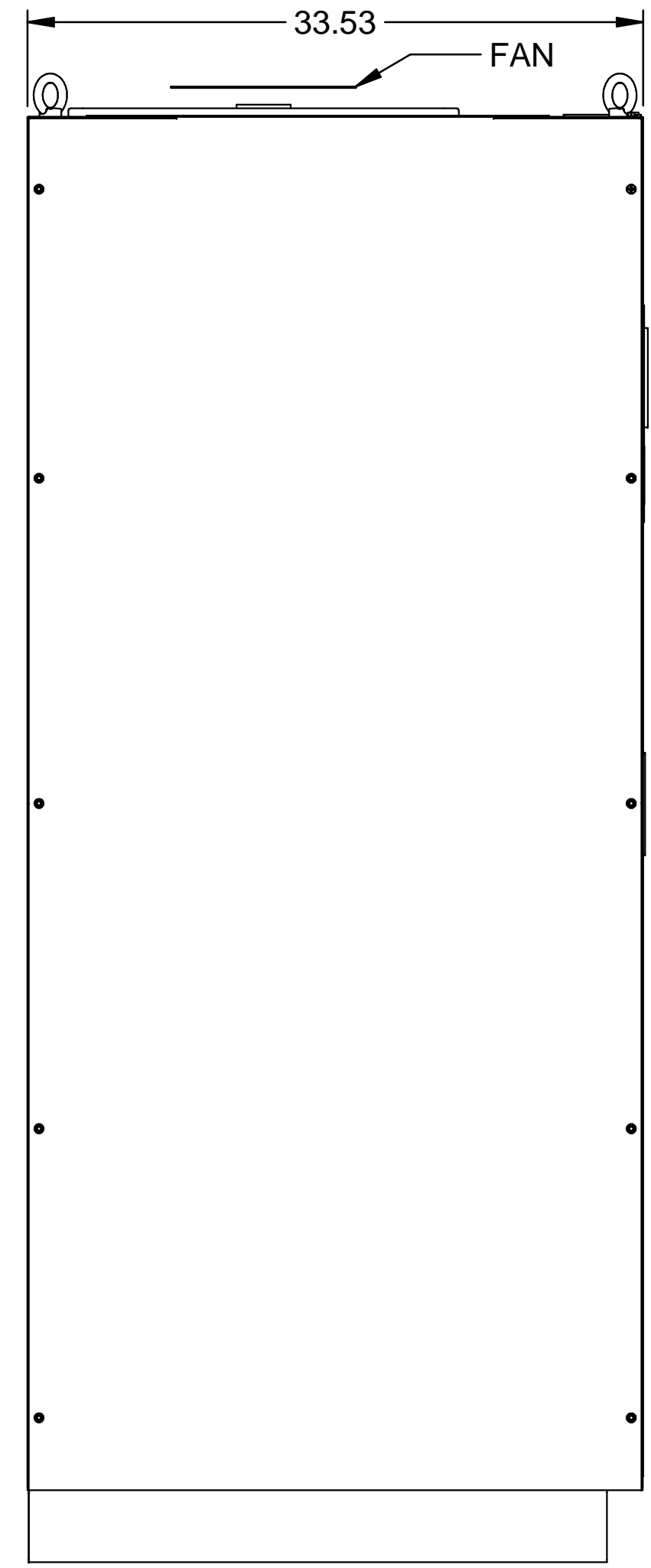

LEFT SIDE

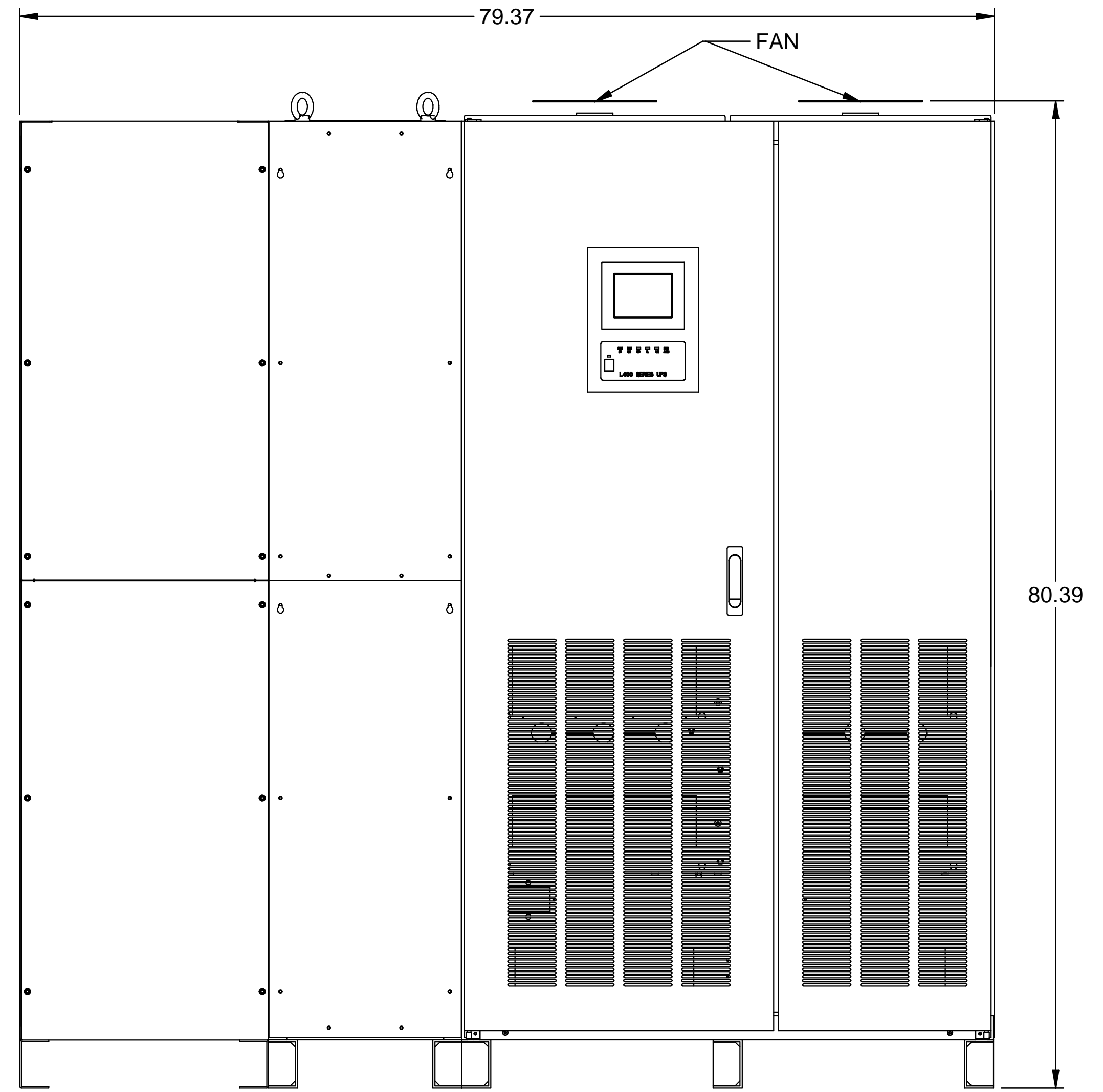

FRONT VIEW

REVISIONS	DATE	BY	DESCRIPTION
0	7/20/2016	G.JOHNSTON	RELEASED FOR CONSTRUCTION
1	4/11/2017	N.RIEMER	REVISED DRAWING TO SHOW UPS

FABRICATION TOLERANCE		DIMENSIONS IN:	SCALE	DRAFTER	DATE	MITSUBISHI ELECTRIC
NOMINAL SIZE	TOLERANCE	IN [MM] (REP)		G.JOHNSTON	7/20/16	
ANGLES	±0.01"	PROPRIETARY This document is the property of Mitsubishi Electric Power Products, Inc. and contains proprietary and confidential information which must not be duplicated, used or disclosed other than as expressly authorized by Mitsubishi Electric Power Products, Inc.		APPROVED	DATE	TITLE OUTLINE-1 DWG. NO. UD-100540 SHEET 2 OF 7 REV. 1
HOLE TO MATERIAL EDGE	±0.01			N.RIEMER	7/20/16	
HOLE TO FORMED EDGE	±0.01			CORE [REFERENCE] DRAWING if there is a core drawing insert that here		
HOLE TO HOLE	±0.005					
FORMED EDGE TO FORMED EDGE	±0.01					
FORMED EDGE TO WELDED EDGE < 48.0	±0.03					
FORMED EDGE TO WELDED EDGE > 48.0	±0.06					
PANEL DISTORTION OVER 48.0in	0.03 MAX					

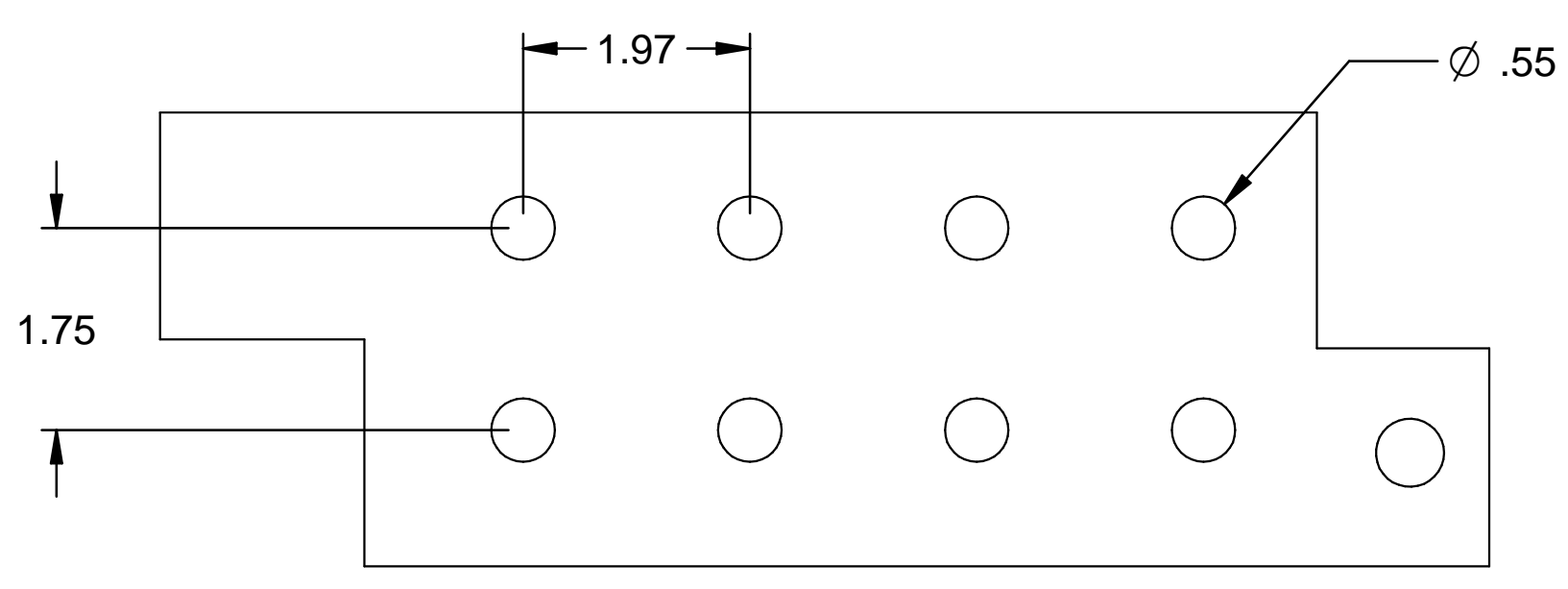

BUSS DETAIL
(TYPICAL)

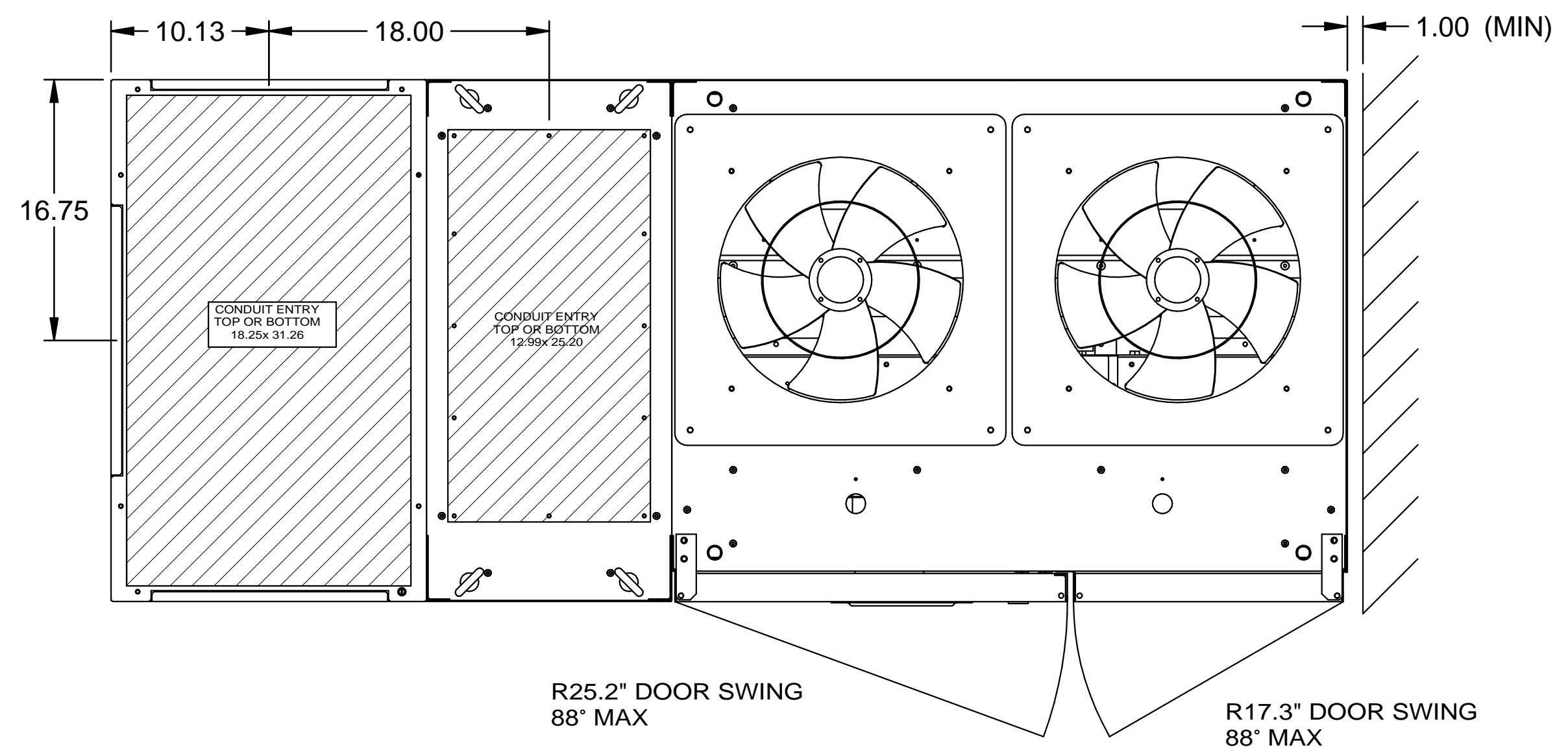

TOP VIEW

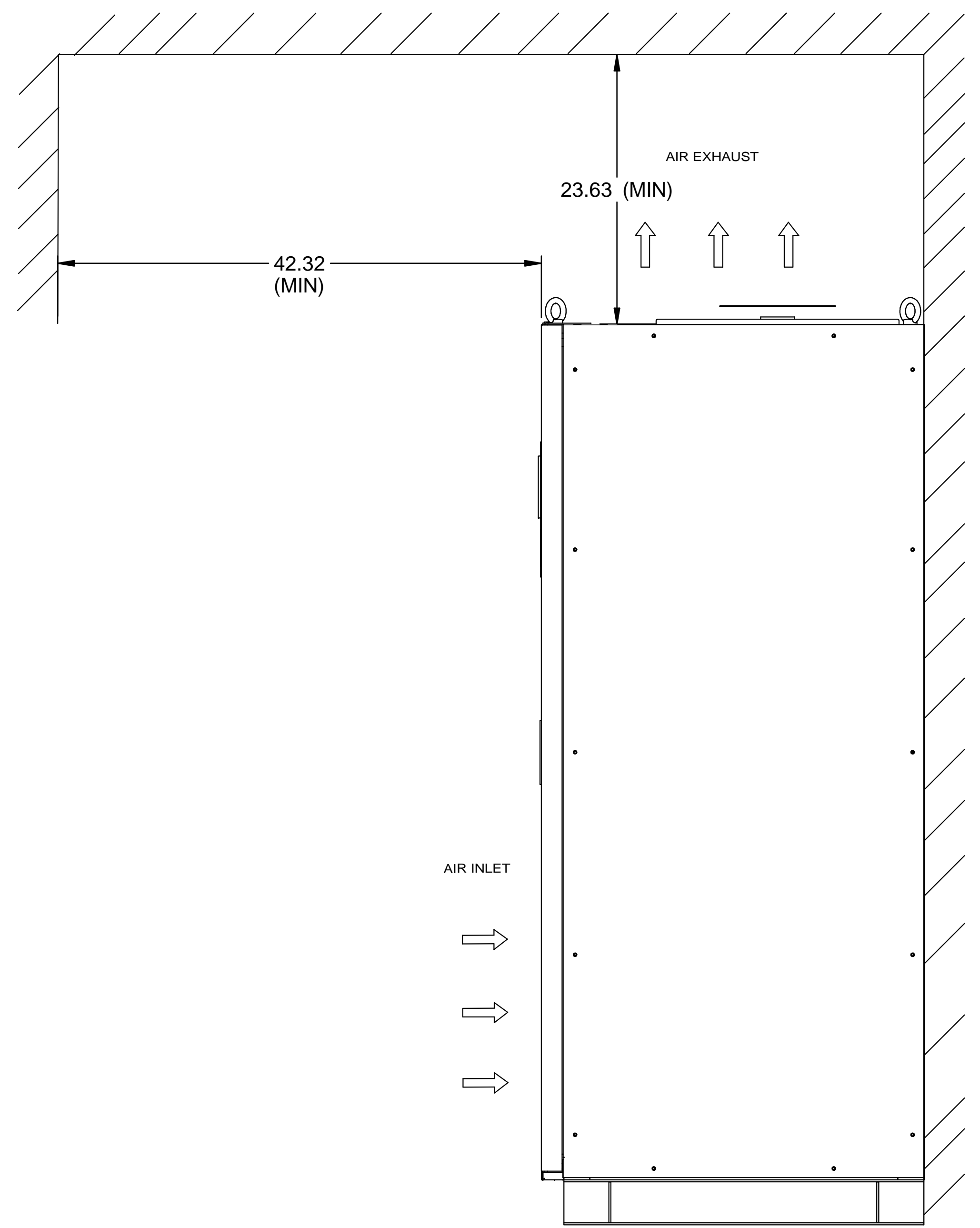

RIGHT SIDE VIEW

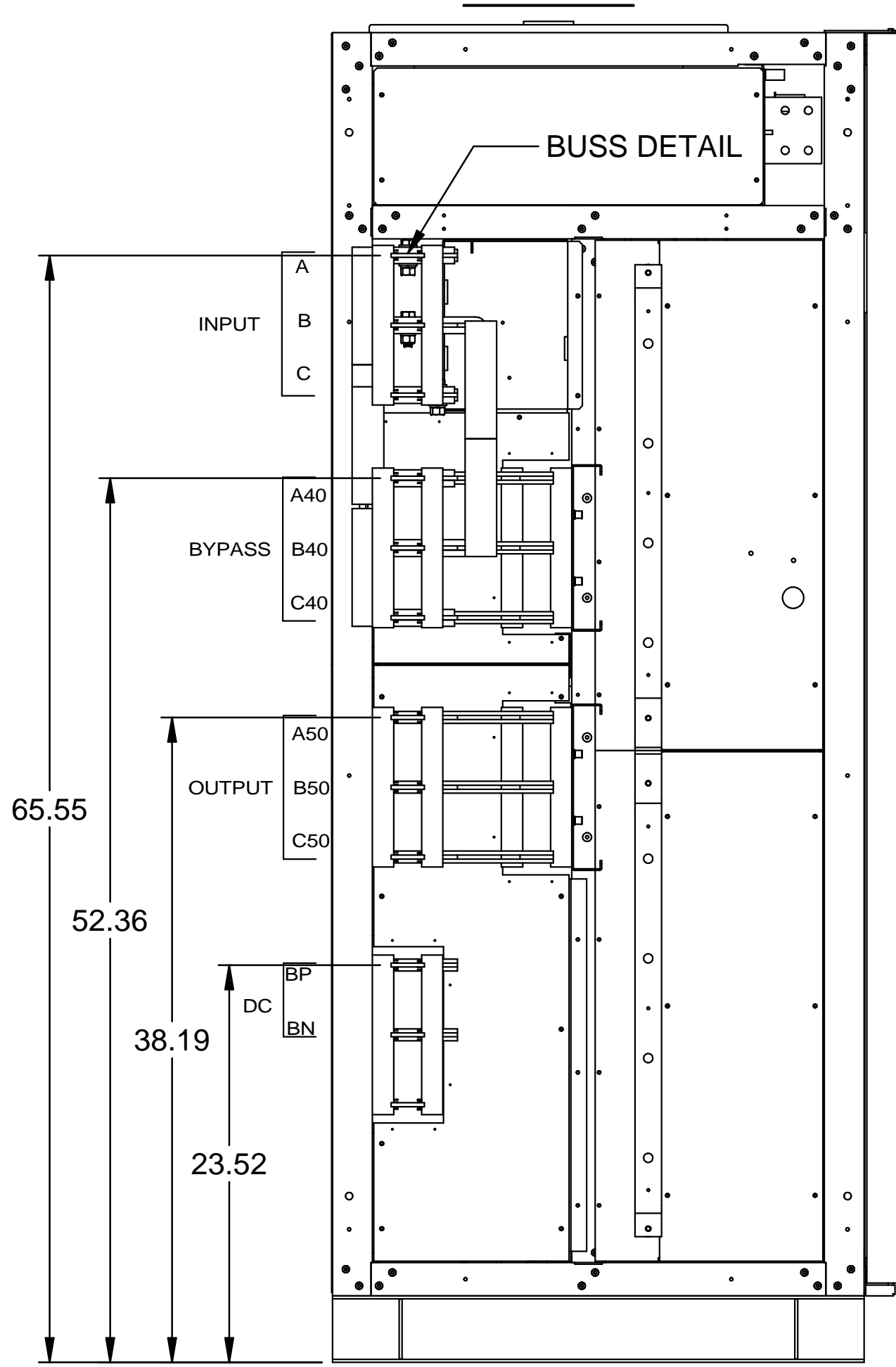

LEFT SIDE
SIDECAR REMOVED FOR CLARITY

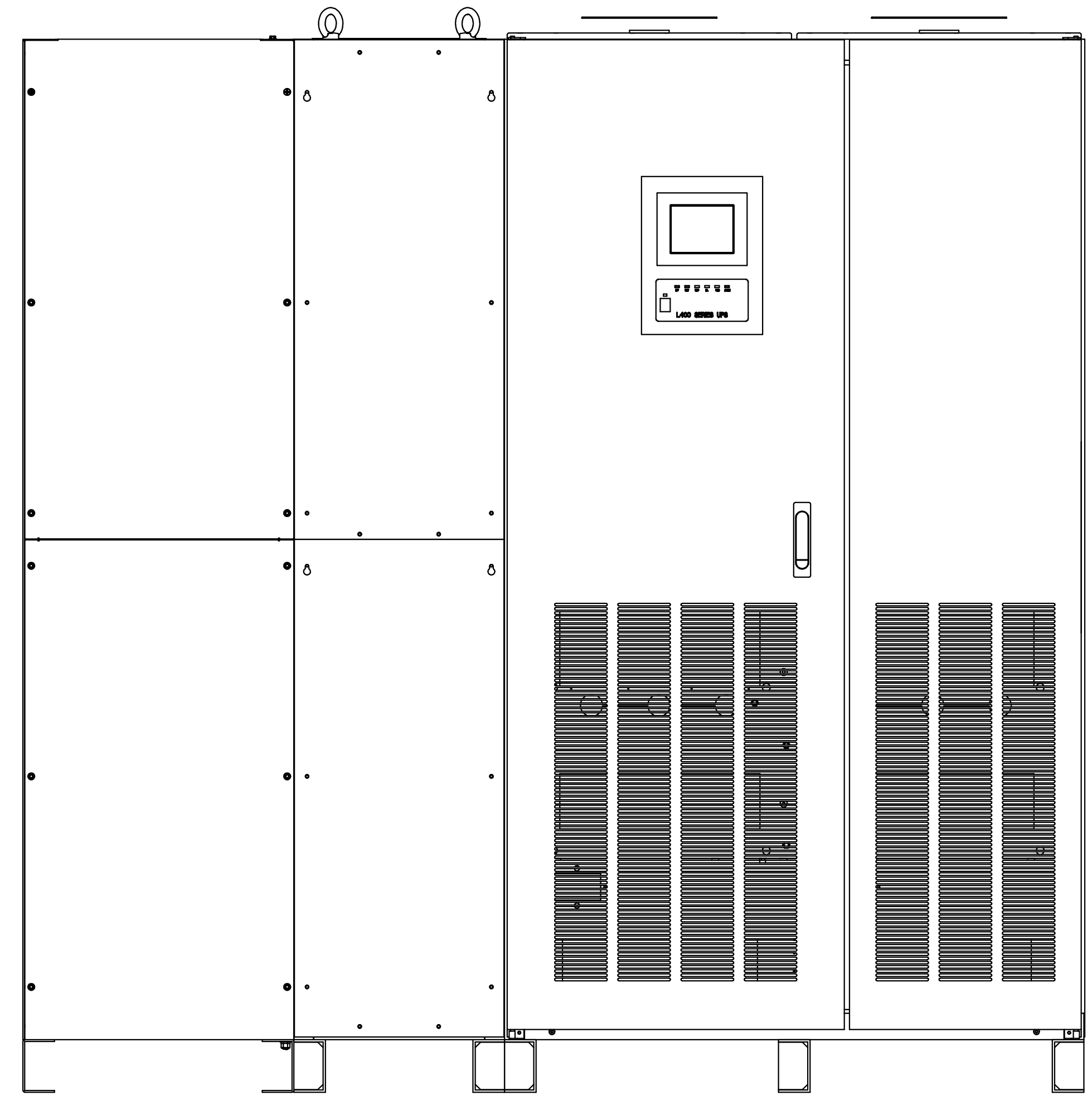

FRONT VIEW

REVISIONS	0. RELEASED FOR CONSTRUCTION G. JOHNSTON 7/20/2016
	1. REVISED DRAWING TO SHOW UPS N. RIEMER 4/11/2017

FABRICATION TOLERANCE	
NOMINAL SIZE	TOLERANCE
ANGLES	±0.01°
HOLE TO MATERIAL EDGE	±0.01
HOLE TO FORMED EDGE	±0.01
HOLE TO HOLE	±0.005
FORMED EDGE TO FORMED EDGE	±0.01
FORMED EDGE TO WELDED EDGE < 48.0	±0.03
FORMED EDGE TO WELDED EDGE > 48.0	±0.06
PANEL DISTORTION OVER 48.0in	0.03 MAX

DIMENSIONS IN:	SCALE
IN [MM] (REP)	
PROPRIETARY This document is the property of Mitsubishi Electric Power Products, Inc. and contains proprietary and confidential information which must not be duplicated, used or disclosed other than as expressly authorized by Mitsubishi Electric Power Products, Inc.	

DRAFTER	DATE
G. JOHNSTON	7/20/16
APPROVED	DATE
N. RIEMER	7/20/16
CORE [REFERENCE] DRAWING If there is a core drawing insert that here	

MITSUBISHI ELECTRIC	TITLE	
	OUTLINE-2	
DWG. NO.	SHEET 3 OF 7	REV.
UD-100540		1

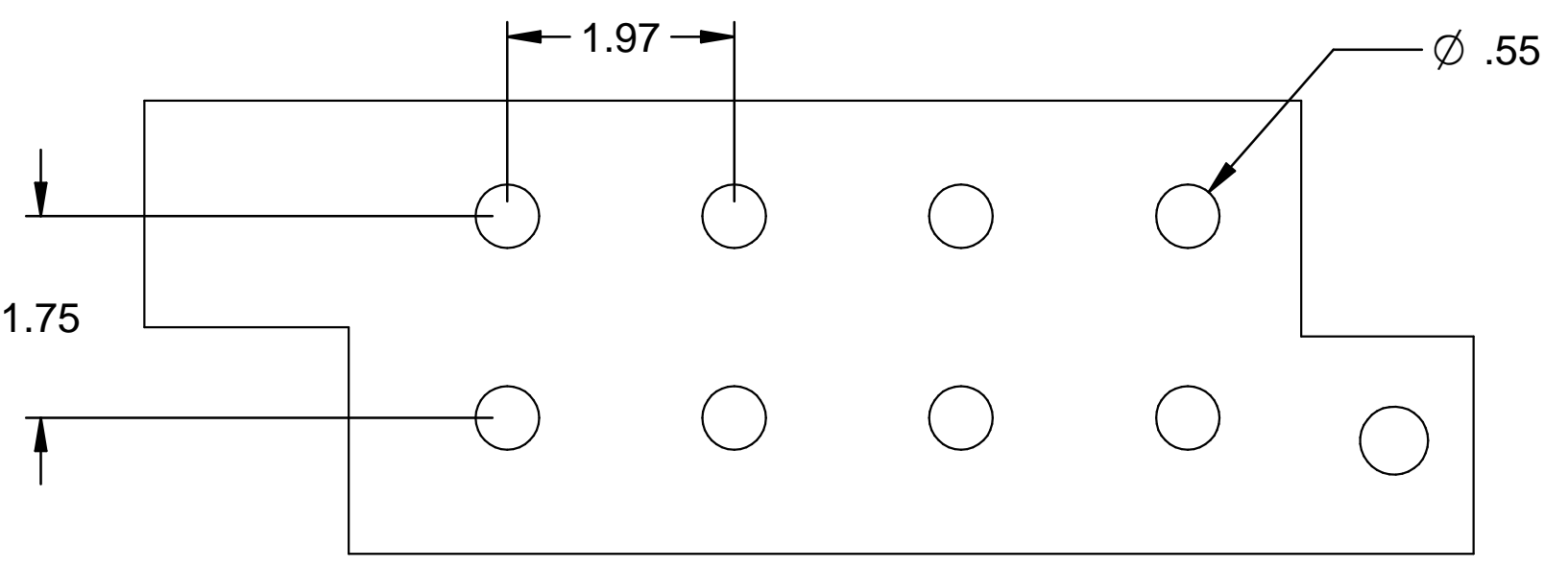

BUSS DETAIL
(TYPICAL)

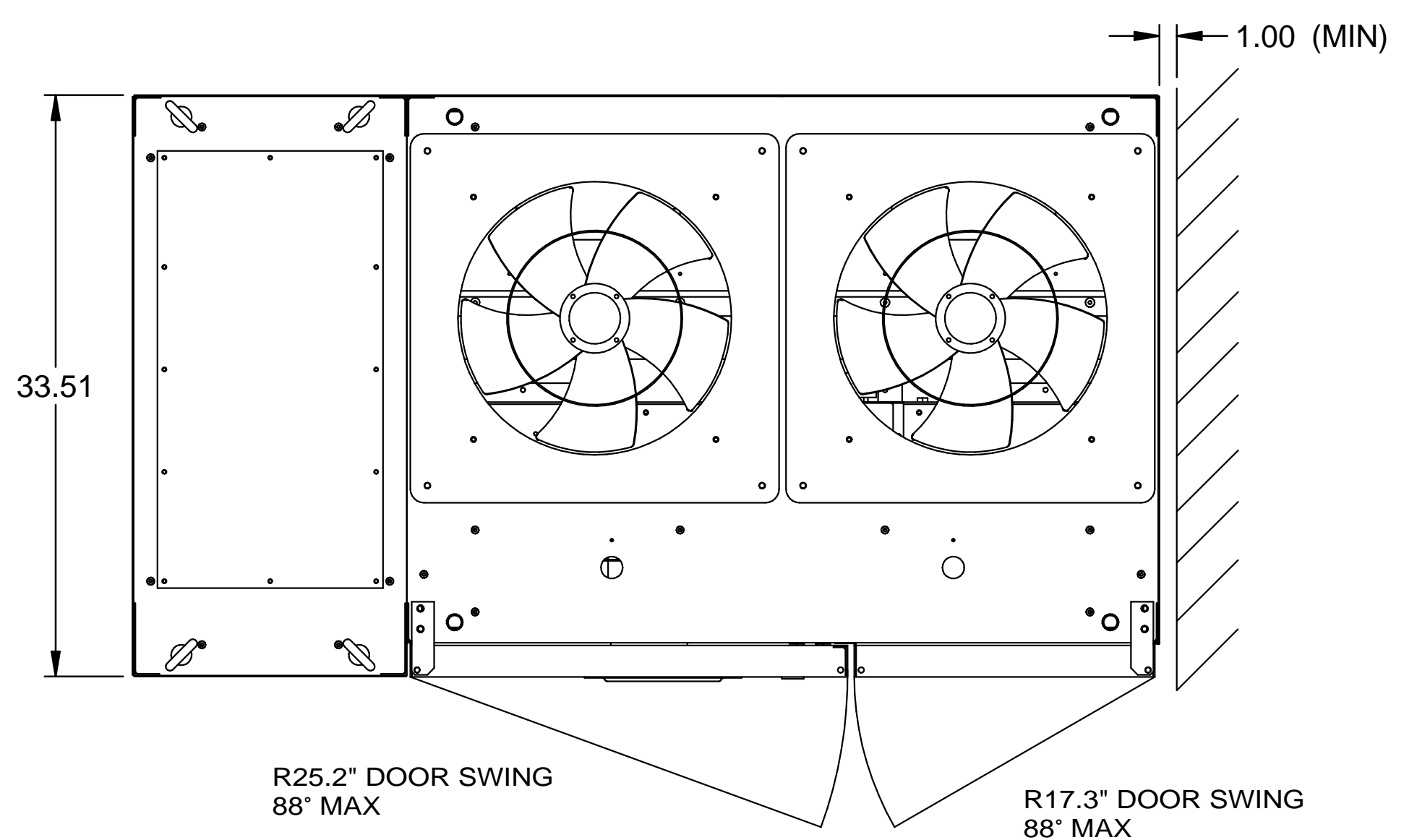

TOP VIEW

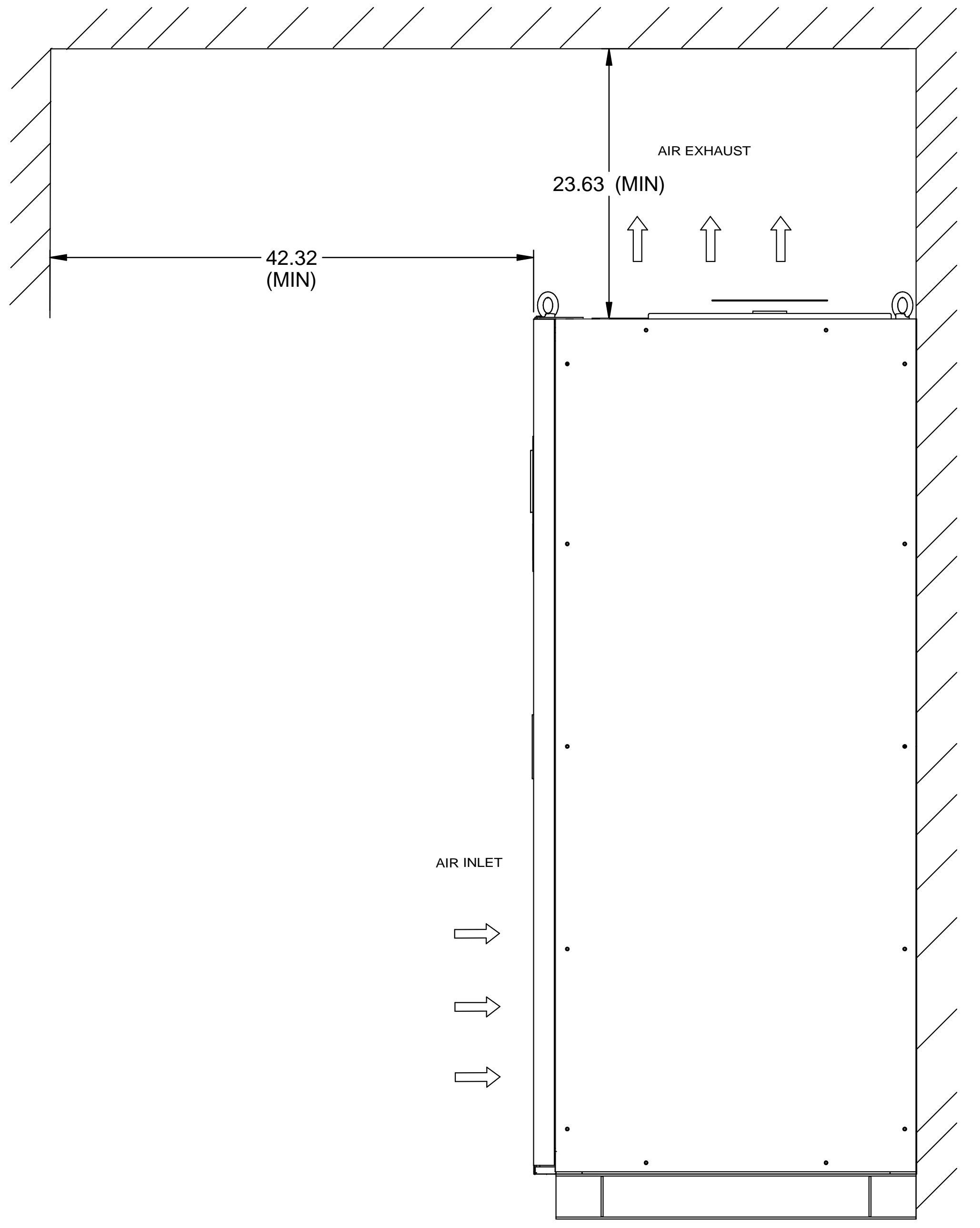

RIGHT SIDE VIEW

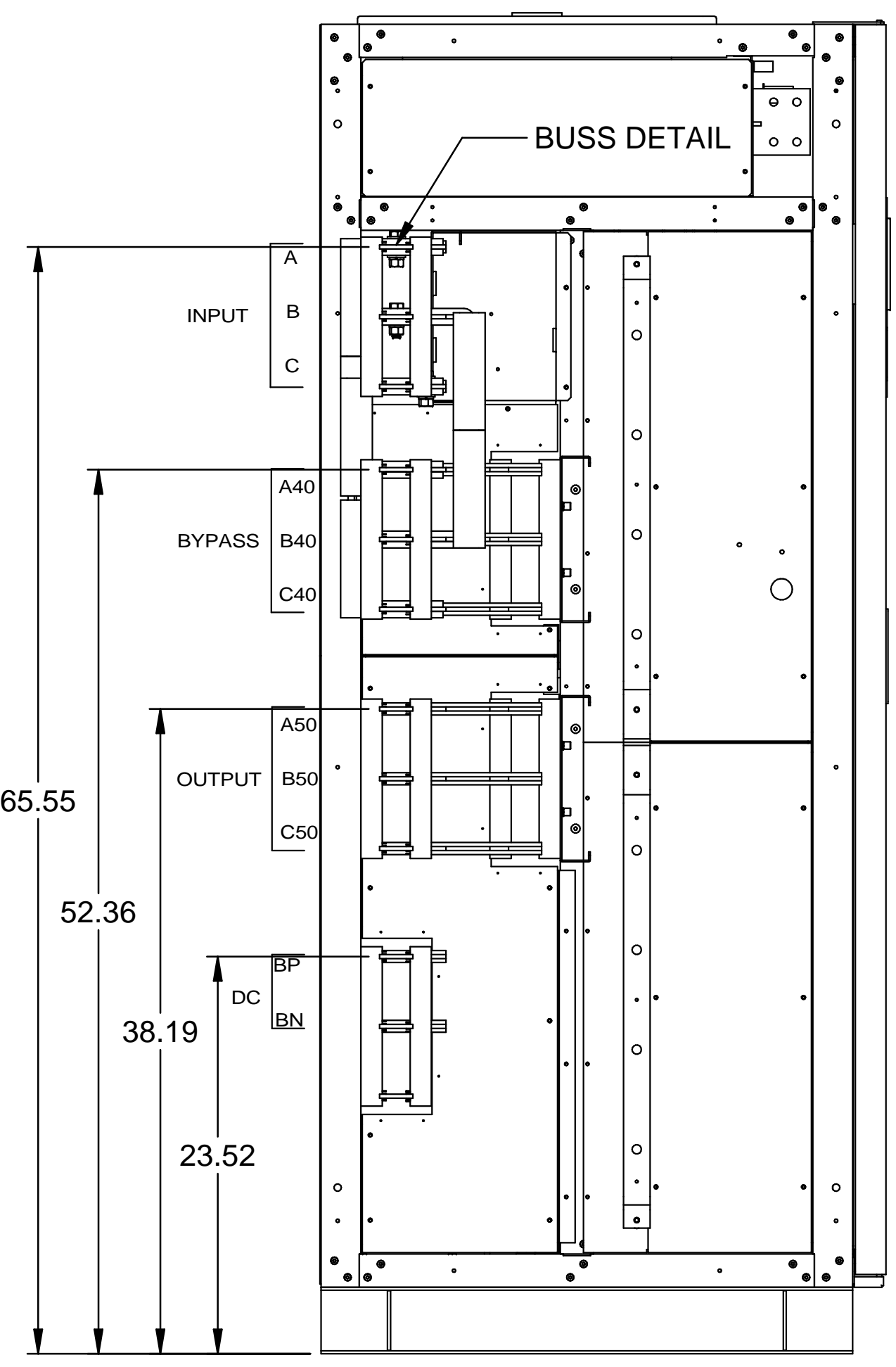

LEFT SIDE
SIDE CAR REMOVED FOR CLARITY

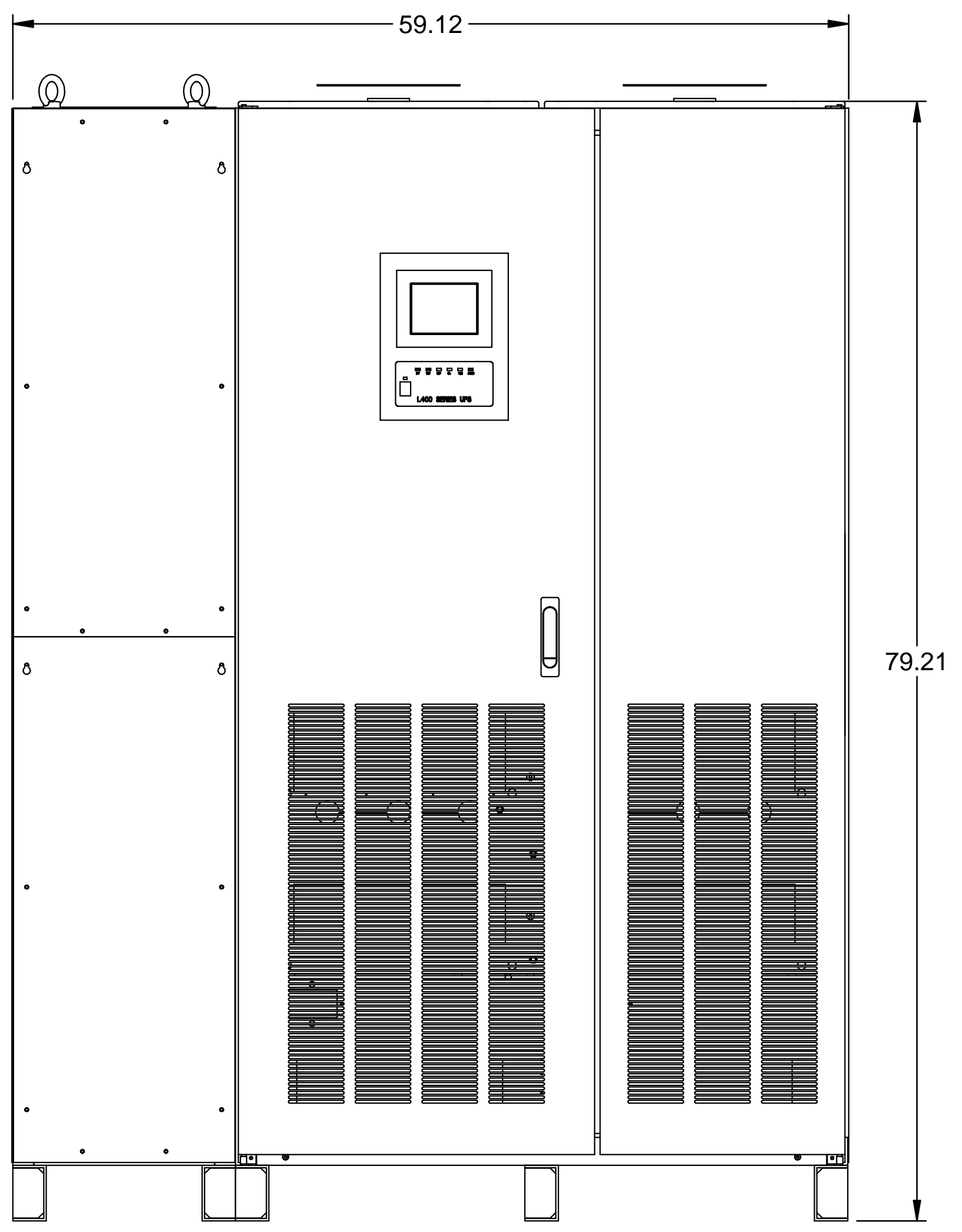

FRONT VIEW

REVISIONS

0	RELEASED FOR CONSTRUCTION	G. JOHNSTON	7/20/2016
1	REVISED DRAWING TO SHOW UPS	N. RIEMER	4/11/2017

FABRICATION TOLERANCE	
NOMINAL SIZE	TOLERANCE
ANGLES	±0.01"
HOLE TO MATERIAL EDGE	±0.01
HOLE TO FORMED EDGE	±0.01
HOLE TO HOLE	±0.005
FORMED EDGE TO FORMED EDGE	±0.01
FORMED EDGE TO WELDED EDGE < 48.0	±0.03
FORMED EDGE TO WELDED EDGE > 48.0	±0.06
PANEL DISTORTION OVER 48.0in	0.03 MAX

DIMENSIONS IN: IN [MM] (REP)	SCALE
PROPRIETARY This document is the property of Mitsubishi Electric Power Products, Inc. and contains proprietary and confidential information which must not be duplicated, used or disclosed other than as expressly authorized by Mitsubishi Electric Power Products, Inc.	

DRAFTER G. JOHNSTON	DATE 7/20/16
APPROVED N. RIEMER	DATE 7/20/16
CORE [REFERENCE] DRAWING If there is a core drawing insert that here	

MITSUBISHI ELECTRIC	TITLE	OUTLINE-3
	DWG. NO.	UD-100540
SHEET 4 OF 7	REV.	1

500kVA 500kW UPS MODULE

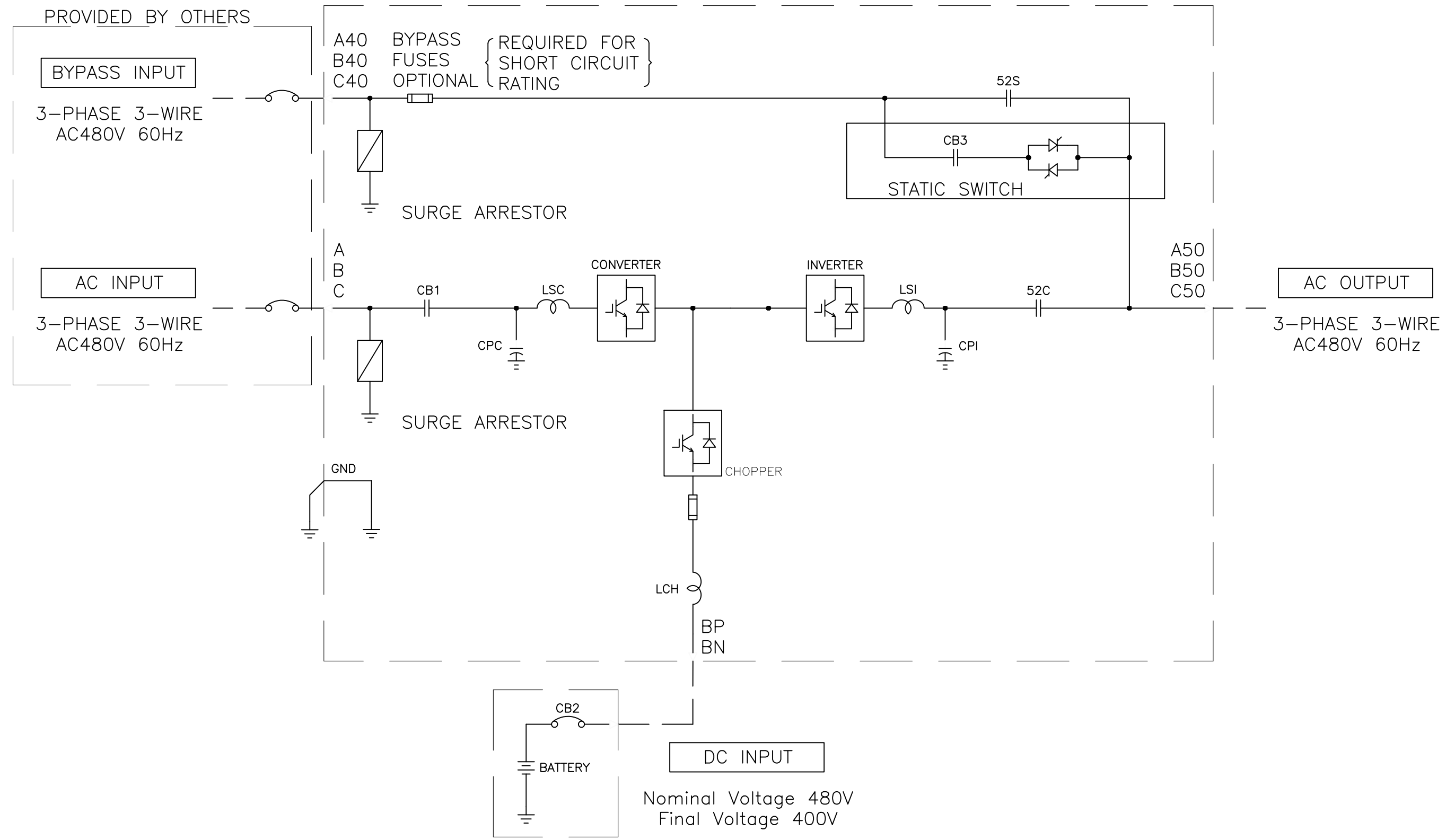

REVISIONS

0	INITIAL RELEASE	7/20/16	GDJ
1	REVISED DRAWING TO SHOW UPS	4/11/17	NR

DIM. IN:	INCHES [MM]	SCALE:	NTS	DRAFTER:	G. JOHNSTON	DATE:	08/13/15
<small>PROPRIETARY THIS DOCUMENT IS PROPERTY OF MITSUBISHI ELECTRIC POWER PRODUCTS, INC. AND CONTAINS PROPRIETARY AND CONFIDENTIAL INFORMATION WHICH MUST NOT BE DUPLICATED, USED OR DISCLOSED OTHER THAN AS EXPRESSLY AUTHORIZED BY MITSUBISHI ELECTRICAL POWER PRODUCTS, INC.</small>				CHECKED:	N. RIEMER	DATE:	08/13/15
REF. DWG. NO.:		ENGINEER:	K. BEAMER	DATE:	08/13/15	TITLE:	
FILE LOCATION:		APPROVED:	K. BEAMER	DATE:	08/13/15	SHEET 5 OF 7	

MITSUBISHI ELECTRIC

SINGLE LINE DIAGRAM

DWG NO.: UD-100540 SHEET 5 OF 7 REV: 1

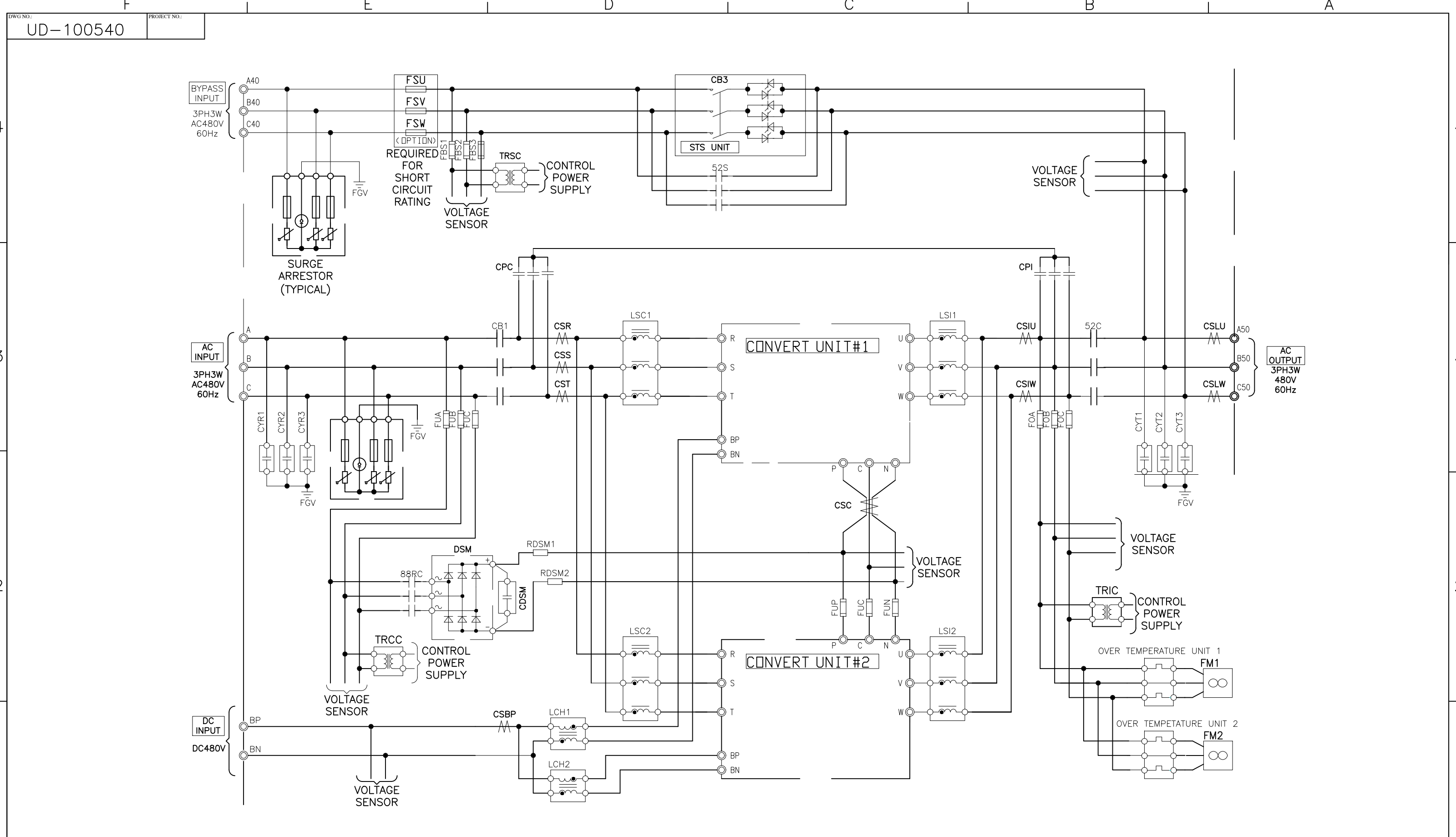

REVISIONS
0 INITIAL RELEASE 7/20/16 GCU
1 REVISED DRAWING TO SHOW UPS 4/11/17 NR

DWG. NO.: UD-100540	PROJECT NO.:
---------------------	--------------

DIM. IN: INCHES [MM]	SCALE: NTS	DRAFTER: G. JOHNSTON	DATE: 08/13/15
<small>PROPRIETARY THIS DOCUMENT IS PROPERTY OF MITSUBISHI ELECTRIC POWER PRODUCTS, INC. AND CONTAINS PROPRIETARY AND CONFIDENTIAL INFORMATION WHICH MUST NOT BE DUPLICATED, USED OR DISCLOSED OTHER THAN AS EXPRESSLY AUTHORIZED BY MITSUBISHI ELECTRICAL POWER PRODUCTS, INC.</small>		CHECKED: N. RIEMER	DATE: 08/13/15
REF. DWG. NO.:	APPROVED: K. BEAMER	ENGINEER: K. BEAMER	DATE: 08/13/15
FILE LOCATION:			

SYSTEM CONFIGURATION	
SHEET 6 OF 7	REV: 1
DWG NO.: UD-100540	

OPTIONAL
REMOTE INTERFACE BOARD FOR REMOTE MONITORING

CN82
(HIF-16P)

UPS STATUS

UPS REMOTE CONTROL

TN2
(TN-20P)

TN1
(TN-20P)

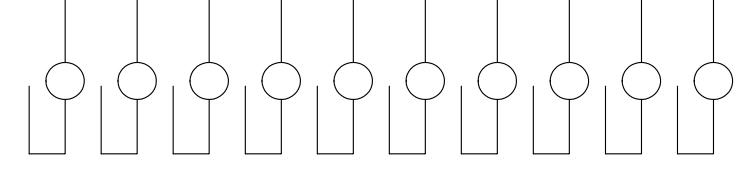
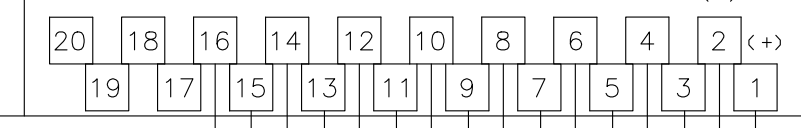
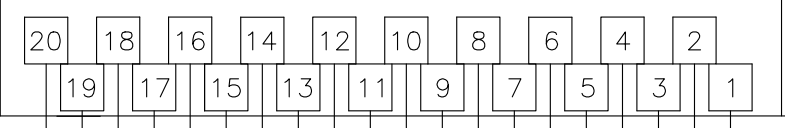

52C CLOSE
OUT8:TOTAL ALARM
OUT7:SPARE
OUT6:OVERLOAD
OUT5:BATTERY LOW VOLTAGE
OUT4:CONVERTER OPERATION
OUT3:BATTERY OPERATION
OUT2:LOAD ON INVERTER
OUT1:LOAD ON BYPASS
SUMMARY ALARM

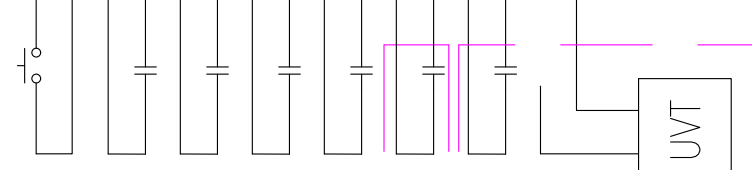

REMOTE EPO
IN4:POWER DEMAND
IN3:BATTERY TEMP.HIGH
IN2:REMOTE INVERTER STOP
IN1:REMOTE INVERTER START
LOAD CIRCUIT SWITCH
52L AX
CB2 AX
BATTERY BREAKER PANEL
CB2 UVT

REVISIONS	
0	INITIAL RELEASE 7/20/16 GCU
1	REVISED DRAWING TO SHOW UPS 4/11/17 NR

DIM. IN:	INCHES [MM]	SCALE:	NTS	DRAFTER:	G. JOHNSTON	DATE:	07/20/16
<small>PROPRIETARY THIS DOCUMENT IS PROPERTY OF MITSUBISHI ELECTRIC POWER PRODUCTS, INC. AND CONTAINS PROPRIETARY AND CONFIDENTIAL INFORMATION WHICH MUST NOT BE DUPLICATED, USED OR DISCLOSED OTHER THAN AS EXPRESSLY AUTHORIZED BY MITSUBISHI ELECTRICAL POWER PRODUCTS, INC.</small>				CHECKED:	N. RIEMER	DATE:	07/20/16
REF. DWG. NO.:		ENGINEER:	K. BEAMER	DATE:	07/20/16	TITLE:	
FILE LOCATION:		APPROVED:	K. BEAMER	DATE:	07/20/16	EXTERNAL SIGNAL TERMINAL BLOCK	
						DWG NO.:	UD-100540
						SHEET 7 OF 7	REV: 1

