

A B C D E F G H I J K L M N O P Q

1

2

3

4

5

6

7

8

9

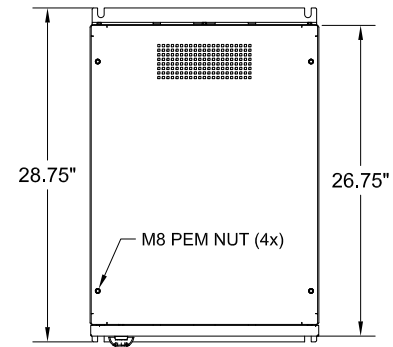

TOP VIEW

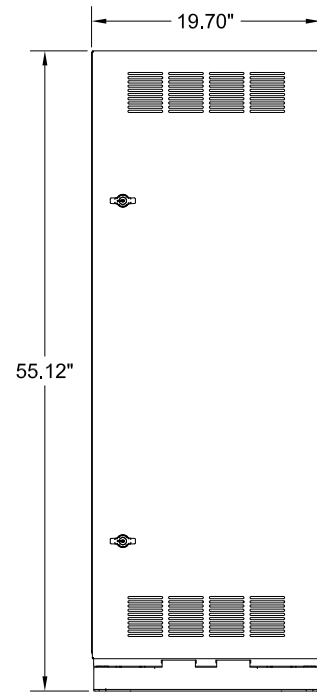

FRONT VIEW

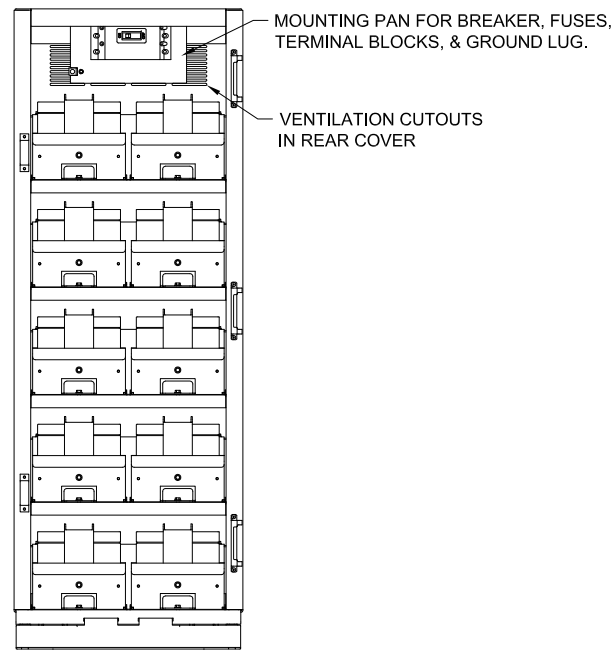

FRONT VIEW (DOOR REMOVED)

RIGHT SIDE VIEW

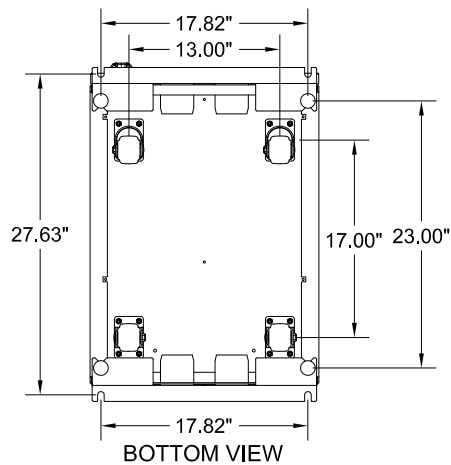
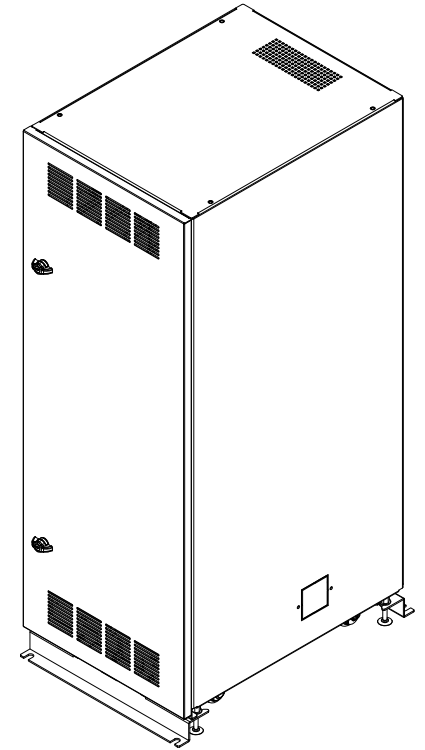
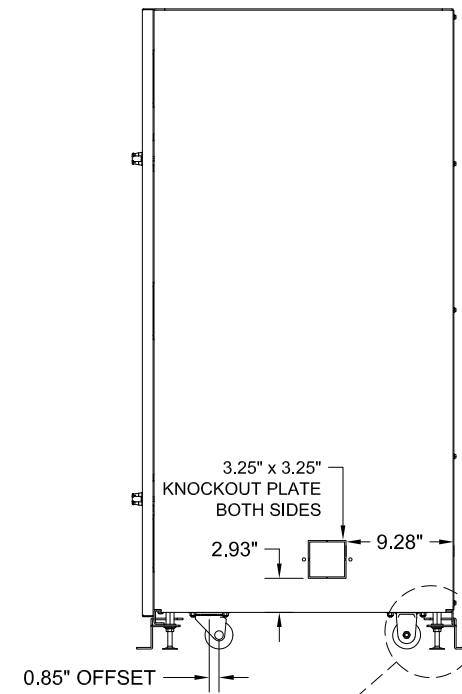

BOTTOM VIEW

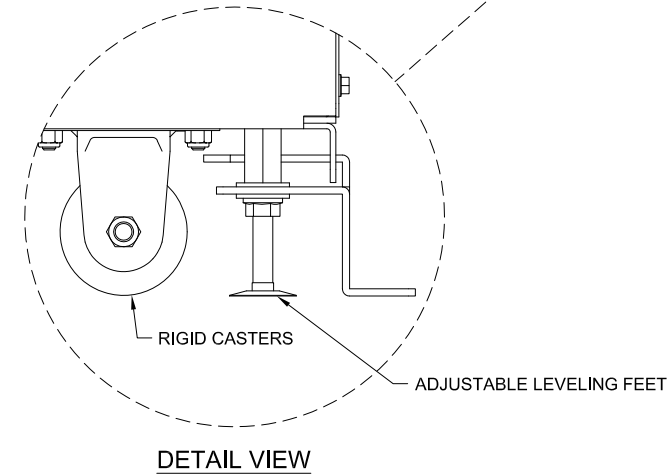

DETAIL VIEW

**CABINET NOTES:**

1. NEMA 1 ENCLOSED BATTERY CABINET.
2. WELDED STEEL CONSTRUCTION.
3. INTERIOR & EXTERIOR FINISH IS N1.5 (BLACK) POWDER COAT , OVEN BAKED FOR CHIP & CORROSION RESISTANT FINISH.
4. BATTERY TRAYS CAN BE ACCESSED FROM THE FRONT OF THE CABINET.
5. CABINET IS SUPPLIED ON SKID WITH HEAVY DUTY RAMP FOR EASY UNLOADING. CABINET IS TO BE MOVED USING THE CABINET CASTERS.

REVISIONS

2 -UPDATED STEEL IN ALL VIEWS.

DIMENSIONS	SCALE	DRAFTER	DATE	<b>MITSUBISHI ELECTRIC POWER PRODUCTS, INC.</b> WARRENDALE, PA.
IN [MM]	NTS	JRL	09/22/11	
<small>THIS DRAWING CONTAINS PROPRIETARY AND CONFIDENTIAL INFORMATION OF C&amp;C POWER, INC. AND HAS BEEN PREPARED FOR THE USE OF MITSUBISHI ELECTRIC POWER PRODUCTS, INC. FOR USE IN CONJUNCTION WITH EQUIPMENT PROVIDED BY C&amp;C POWER, INC. UNAUTHORIZED REPRODUCTION, IN WHOLE OR IN PART, WITHOUT WRITTEN PERMISSION OF C&amp;C POWER, INC. IS PROHIBITED. © 2011 C&amp;C POWER, INC.</small>				
REF DWG. NO. -		ENGINEER	DATE	
FILE LOCATION:		APPROVED	DATE	
			TITLE	1100 SERIES BATTERY CABINET
			DWG NO.	BC16-SD01-1 REV 2
			REV.	<b>2</b>

A B C D E F G H I J K L M N O P Q

1  
2  
3  
4  
5  
6  
7  
8  
9

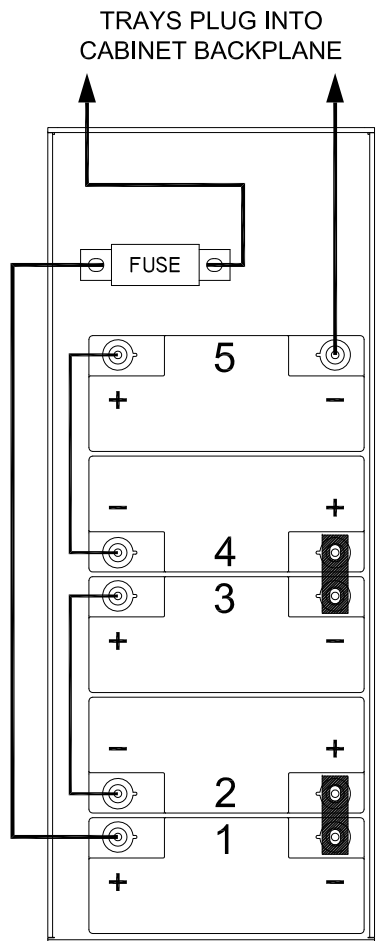

TRAYS 1-4

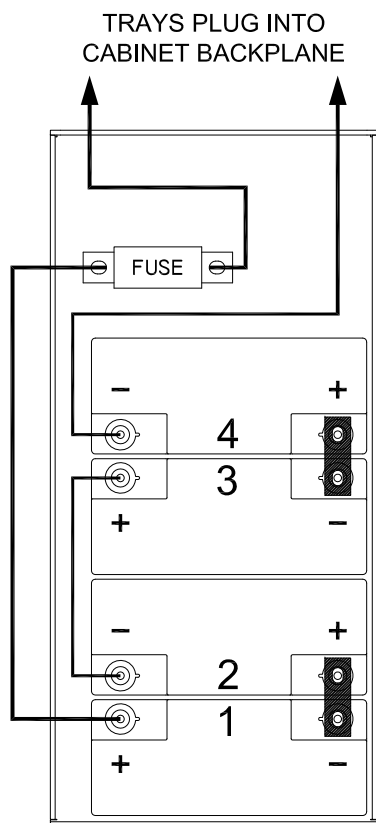

TRAY 5

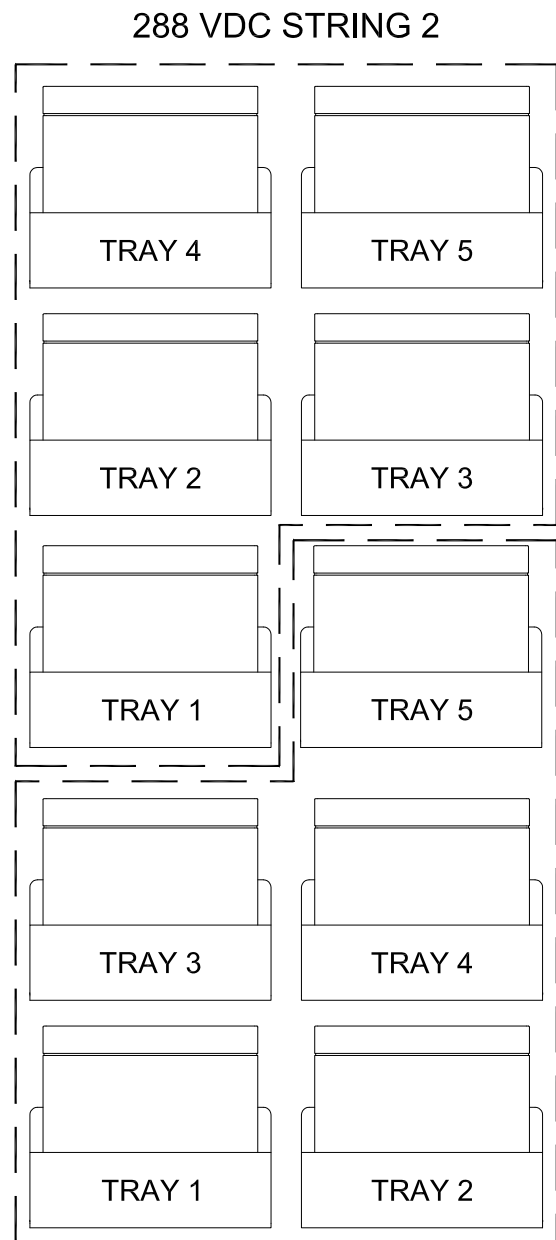
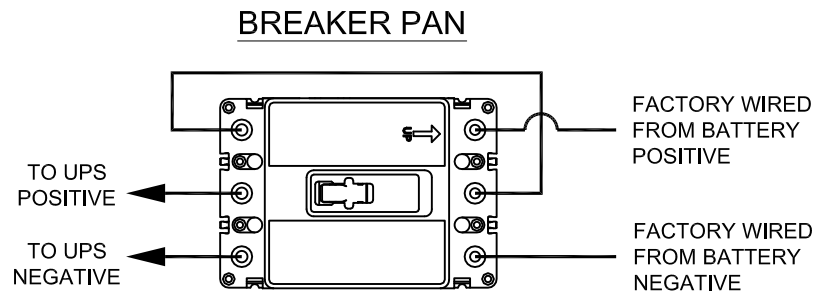

288 VDC STRING 1

**ELECTRICAL NOTES:**

1. ALL INTERNAL WIRING IS UL LISTED, MTW, STYLE, 105C, EXTRA FLEXIBLE CABLE.
2. BATTERY TRAY FUSE IS UL RECOGNIZED.
3. BREAKER IS UL LISTED.
4. TERMINAL BLOCK IS UL RECOGNIZED, 600V RATED.
5. BATTERY CABINETS WITH BREAKERS ARE SHIPPED WITH BREAKER IN THE TRIPPED POSITION.
6. CABLES FROM BATTERY CABINET TO UPS SYSTEM ARE SUPPLIED BY OTHERS.
7. ALL CONTROL WIRING IS POWERED FROM AN OUTSIDE SOURCE.
8. GROUND CONNECTION IS #14-1/0 MECHANICAL LUG.
9. ALL BREAKER, GROUND LUG, FUSE HOLDER, AND TERMINAL BLOCK CONNECTIONS ARE MECHANICAL LUG TYPE. THESE CONNECTIONS ACCEPT BARE WIRE.
10. FOR BATTERY TORQUE SPEC REFER TO BATTERY LAYOUT DRAWING INSIDE BATTERY CABINET, OR SEE LABEL ON BATTERY CASE.
11. FOR TERMINAL BLOCK TORQUE SPEC REFER TO LABEL ON TERMINAL BLOCK.
12. FOR CIRCUIT BREAKER TORQUE INFORMATION REFER TO LABEL ON BREAKER CASE.

1 - UPDATED WIRING.

REVISIONS

DIMENSIONS IN [MM]	SCALE NTS	DRAFTER JRL	DATE 07/13/11	<b>MITSUBISHI ELECTRIC POWER PRODUCTS, INC.</b> WARRENDALE, PA.
<small>THIS DRAWING CONTAINS PROPRIETARY AND CONFIDENTIAL INFORMATION OF C&amp;C POWER, INC. AND HAS BEEN PREPARED FOR THE USE OF MITSUBISHI ELECTRIC POWER PRODUCTS, INC. FOR USE IN CONJUNCTION WITH EQUIPMENT PROVIDED BY C&amp;C POWER, INC. UNAUTHORIZED REPRODUCTION, IN WHOLE OR IN PART, WITHOUT WRITTEN PERMISSION OF C&amp;C POWER, INC. IS PROHIBITED. © 2011 C&amp;C POWER, INC.</small>				
REF DWG. NO. -		CHECKED	DATE	TITLE <b>1100 SERIES BATTERY CABINET</b>
FILE LOCATION:		ENGINEER	DATE	DWG NO. BC16-SD01-2 REV 1
		APPROVED	DATE	REV. <b>1</b>