

MITSUBISHI 9900C 1050kVA UPS DIRECT CABLE CONFIGURATION

CUSTOMER -

PROJECT NUMBER -

PROJECT LOCATION -

TABLE OF CONTENTS

SHEET NO.	TITLE
01	COVER SHEET
02	UPS & SIDECAR DIRECT CABLE CONFIGURATION
03	1050kVA UPS DETAIL
04	UPS ELECTRICAL SCHEMATIC
05	UPS ONE-LINE DIAGRAM
06	UPS CONTROL WIRING DIAGRAM
07	
08	
09	
10	
11	
12	
13	
14	
15	

REVISIONS
4. DELETED BUSS DETAILS ADDED REFERENCE FOR SHIPPING SPLIT ASSEMBLY DETAILS P. GUERRIERI 10/6/2016
5. ADDED CENTER OF MASS DIMENSION TO SHEET 1 AND COVER SHEET Z.ZAJAC 11/21/17
6. HID PANELS ON SHEET 3 FOR DIMENSIONS J.MENDEZ 3/27/2018
7. ADDED CONDUIT ENTRY LOCATIONS Z.ZAJAC 8/14/2018

FABRICATION TOLERANCE	
NOMINAL SIZE	TOLERANCE
ANGLES	±0.01°
HOLE TO MATERIAL EDGE	±0.01
HOLE TO FORMED EDGE	±0.01
HOLE TO HOLE	±0.005
FORMED EDGE TO FORMED EDGE	±0.01
FORMED EDGE TO WELDED EDGE < 48.0	±0.03
FORMED EDGE TO WELDED EDGE > 48.0	±0.06
PANEL DISTORTION OVER 48.0in	0.03 MAX

DIMENSIONS IN:
IN [MM] (REP)

SCALE
- NTS -

PROPRIETARY
This document is the property of Mitsubishi Electric Power Products, Inc. and contains proprietary and confidential information which must not be duplicated, used or disclosed other than as expressly authorized by Mitsubishi Electric Power Products, Inc.

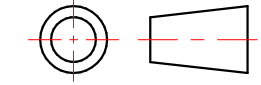
DRAFTER P. GUERRIERI	DATE 10/6/16
APPROVED N. RIEMER	DATE 10/10/16
	
CORE [REFERENCE] DRAWING	

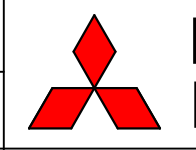
 MITSUBISHI ELECTRIC	TITLE
	9900C UPS MODULE
DWG. NO.	SHEET 1 OF 6 REV.
UD-100354	7

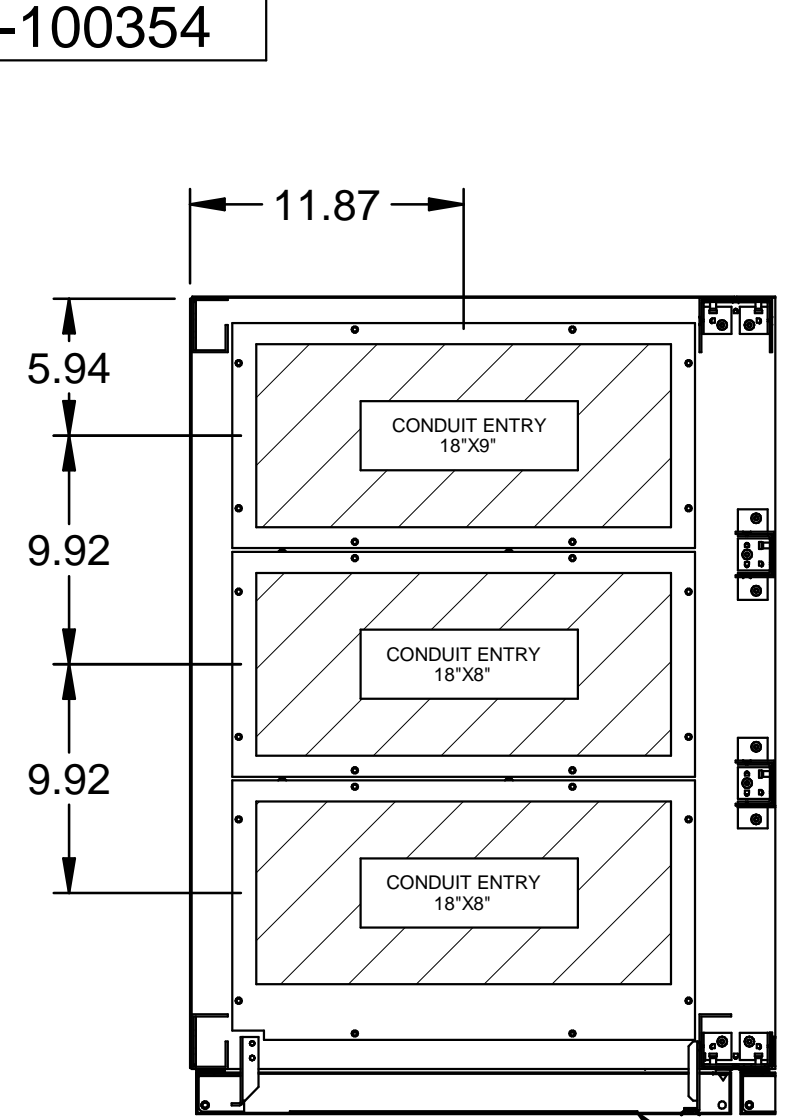

SECTION A-A
BOTTOM CONDUIT ENTRY

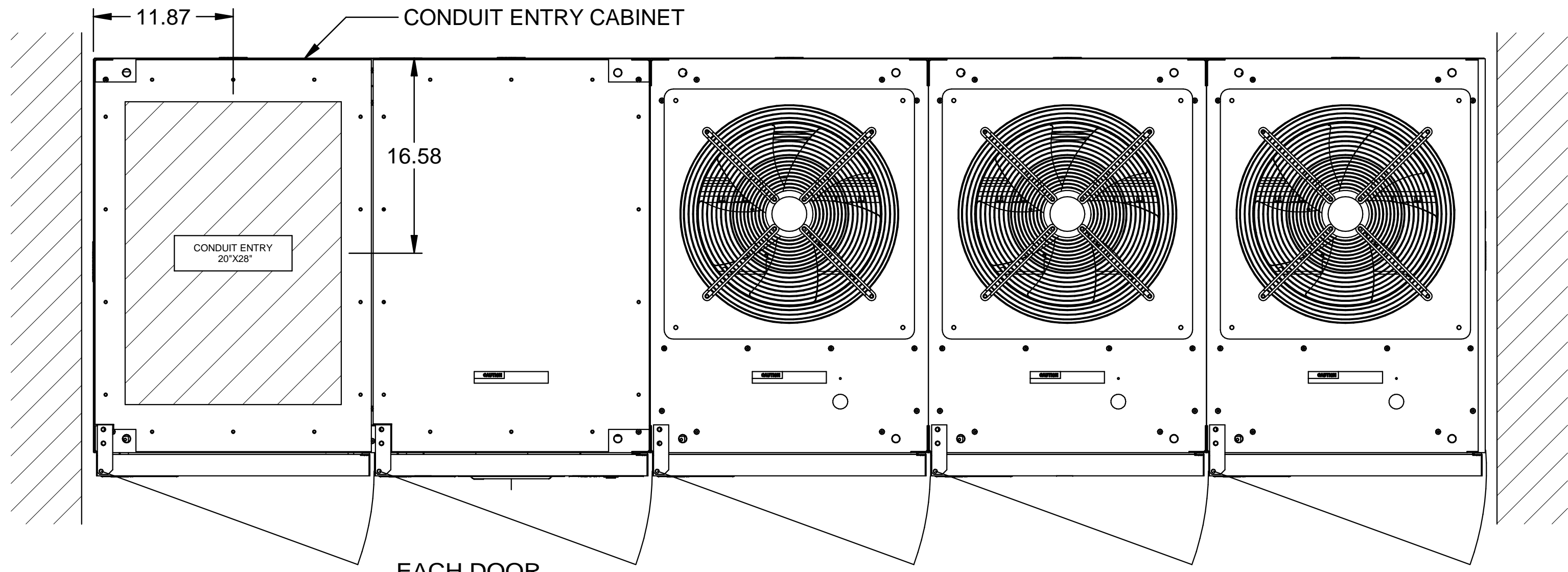

TOP VIEW

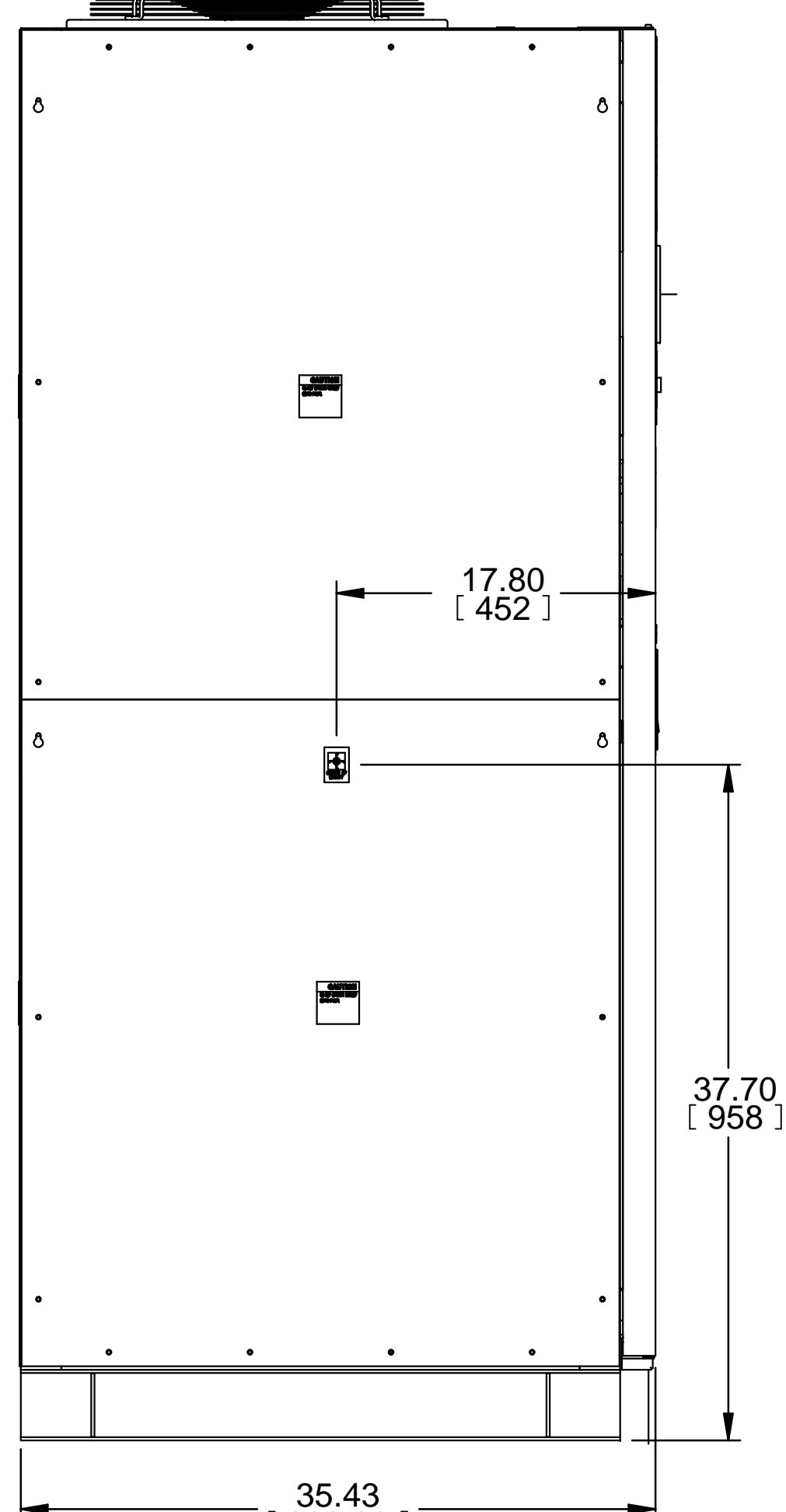

LEFT SIDE VIEW

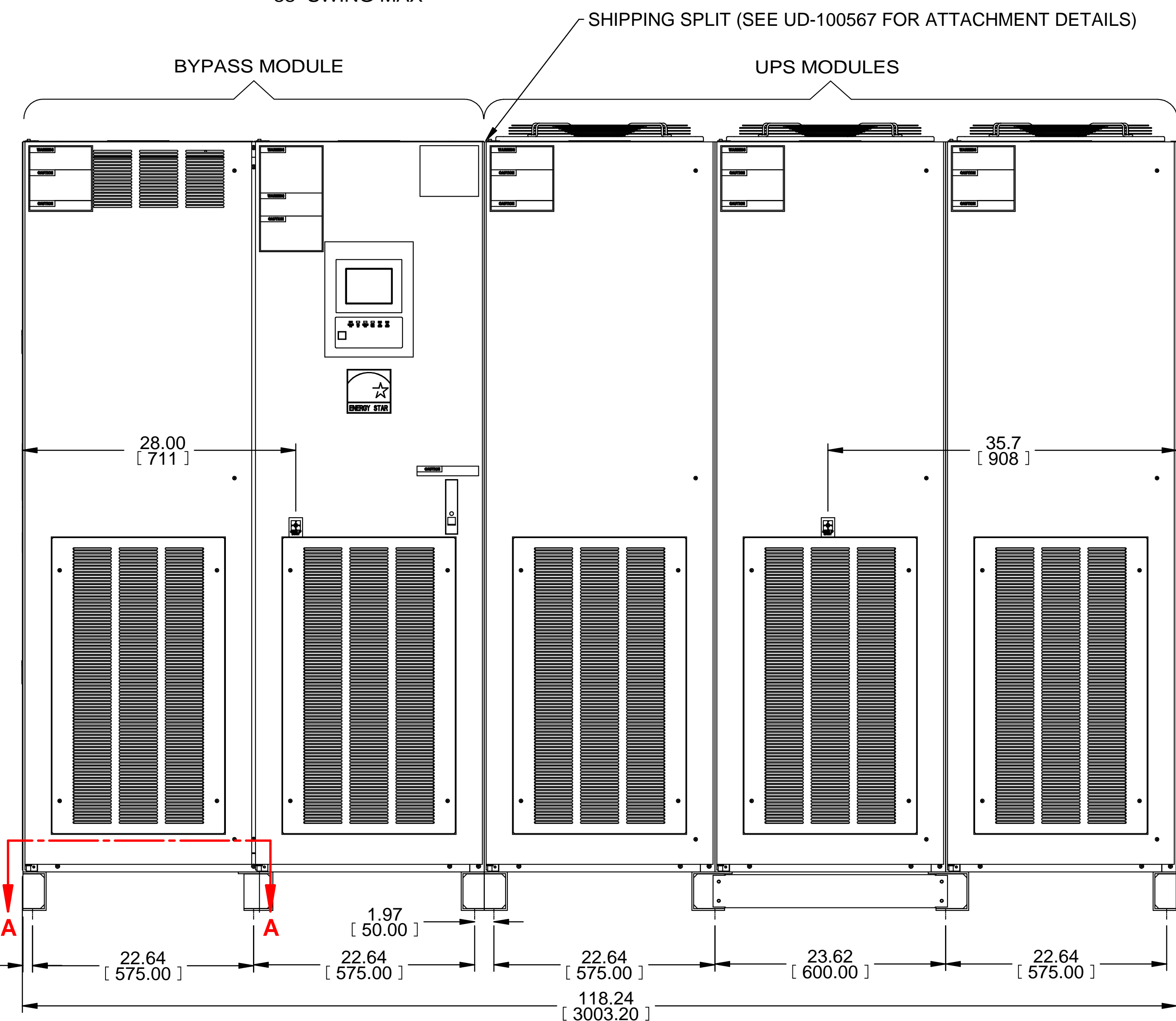

FRONT VIEW

NOTES:

1. DIMENSIONS ARE SHOWN IN INCHES [MILLIMETERS]
2. SIDE SPACE 1.00 [25] IS NOT REQUIRED WHEN SIDECARS ARE USED.
3. CABINET SHOULD BE MAINTAINED UPRIGHT WITHIN +/-15 DEGREES DURING HANDLING.
4. EACH BASE HAS 2 OR 4 0.8 INCH [20] DIAMETER HOLES TO FIX UPS ON THE GROUND.
5. APPROXIMATE WEIGHT:

UPS MODULES	4960 LBS. (2250 kg)
BYPASS MODULE	1653 LBS. (750 kg)
TOTAL	6613 LBS. (3000 kg)
6. EXTERNAL WIRES OR CABLES SHALL BE PROVIDED BY CUSTOMERS FOR AC-INPUT, DC-INPUT, BYPASS-INPUT, AND AC-OUTPUT. (OUT OF MITSUBISHI PROVISION)
7. ROTATION OF A, B, AND C PHASE IS CLOCKWISE.
8. DC BUSS HAS PROVISIONS FOR EIGHT (8) NEMA 2 HOLE LUGS
9. AC BUSS HAS PROVISIONS FOR SIX (6) NEMA 2 HOLE LUGS

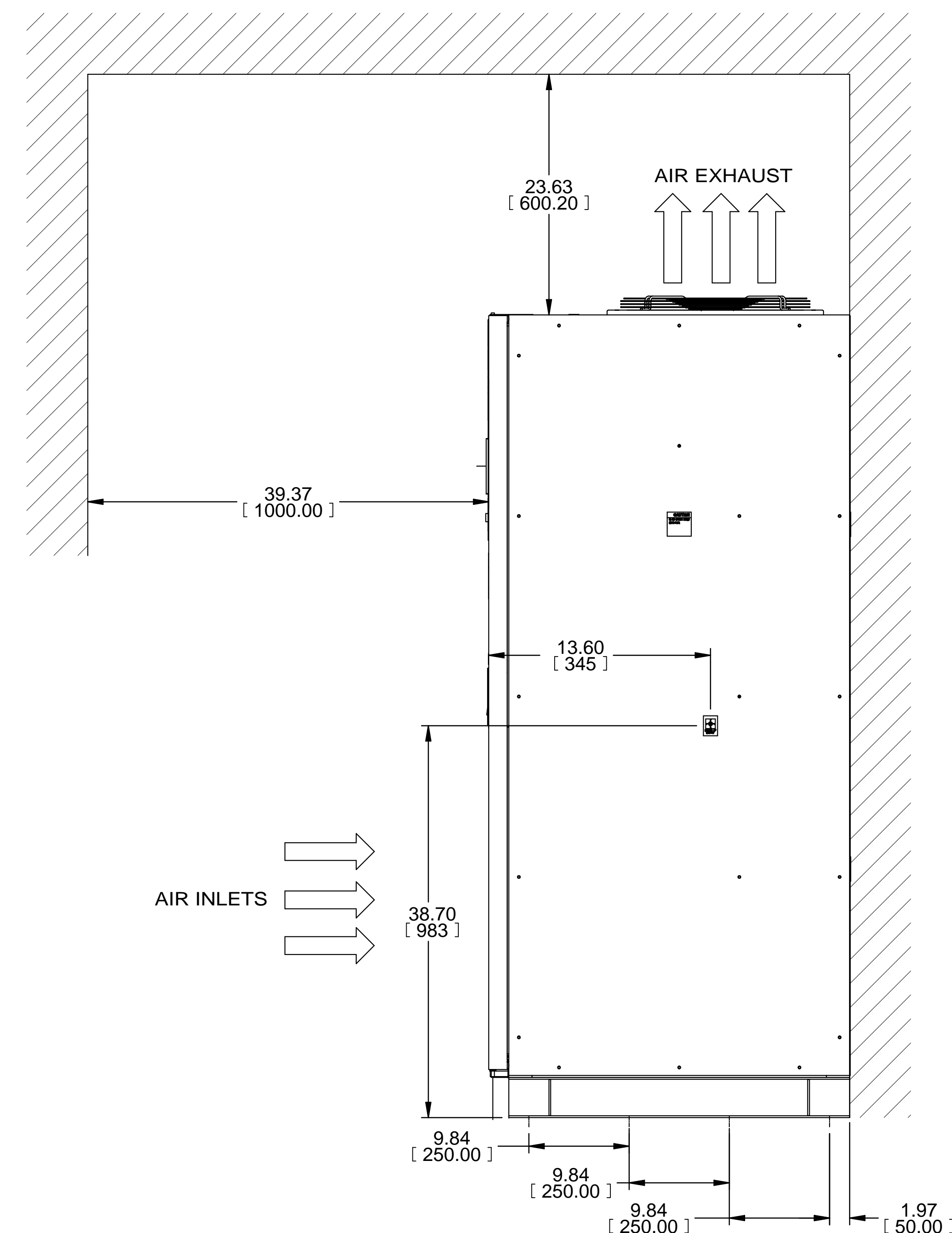

RIGHT SIDE VIEW

REVISIONS	DESCRIPTION	DATE
4.	DELETED BUSS DETAILS ADDED REFERENCE FOR SHIPPING SPLIT ASSEMBLY DETAILS P. GUERRIERI 10/6/2016	
5.	ADDED CENTER OF MASS DIMENSIONS TO SHEET 1 AND COVER SHEET Z.ZAJAC 11/21/17	
6.	HID PANELS ON SHEET 3 FOR DIMENSIONS J.MENDEZ 3/27/2018	
7.	ADDED CONDUIT ENTRY LOCATIONS Z.ZAJAC 8/14/2018	

FABRICATION TOLERANCE		DIMENSIONS IN:	SCALE	DRAFTER	DATE
NOMINAL SIZE	TOLERANCE	IN [MM] (REP)	- NTS -	P. GUERRIERI	10/6/16
ANGLES	±0.01°				
HOLE TO MATERIAL EDGE	±0.01				
HOLE TO FORMED EDGE	±0.01				
HOLE TO HOLE	±0.005				
FORMED EDGE TO FORMED EDGE	±0.01				
FORMED EDGE TO WELDED EDGE < 48.0	±0.03				
FORMED EDGE TO WELDED EDGE > 48.0	±0.06				
PANEL DISTORTION OVER 48.0in	0.03 MAX				

PROPRIETARY This document is the property of Mitsubishi Electric Power Products, Inc. and contains proprietary and confidential information which must not be duplicated, used or disclosed other than as expressly authorized by Mitsubishi Electric Power Products, Inc.		APPROVED N. RIEMER	DATE 10/10/16	MITSUBISHI ELECTRIC
CORE [REFERENCE] DRAWING			TITLE 9900C UPS MODULE	
			DWG. NO. UD-100354	SHEET 2 OF 6 REV. 7

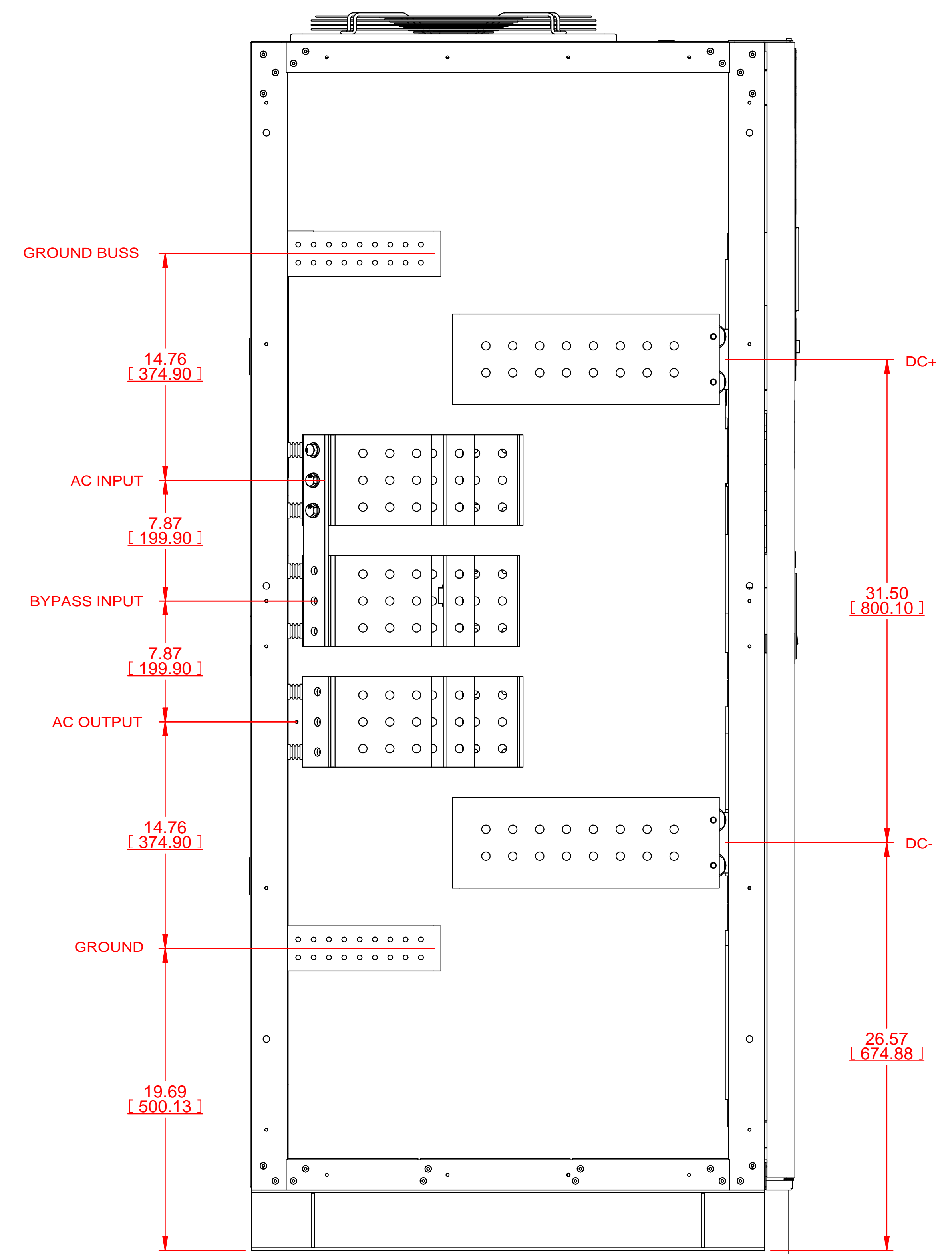

LEFT SIDE VIEW
PANELS NOT SHOWN

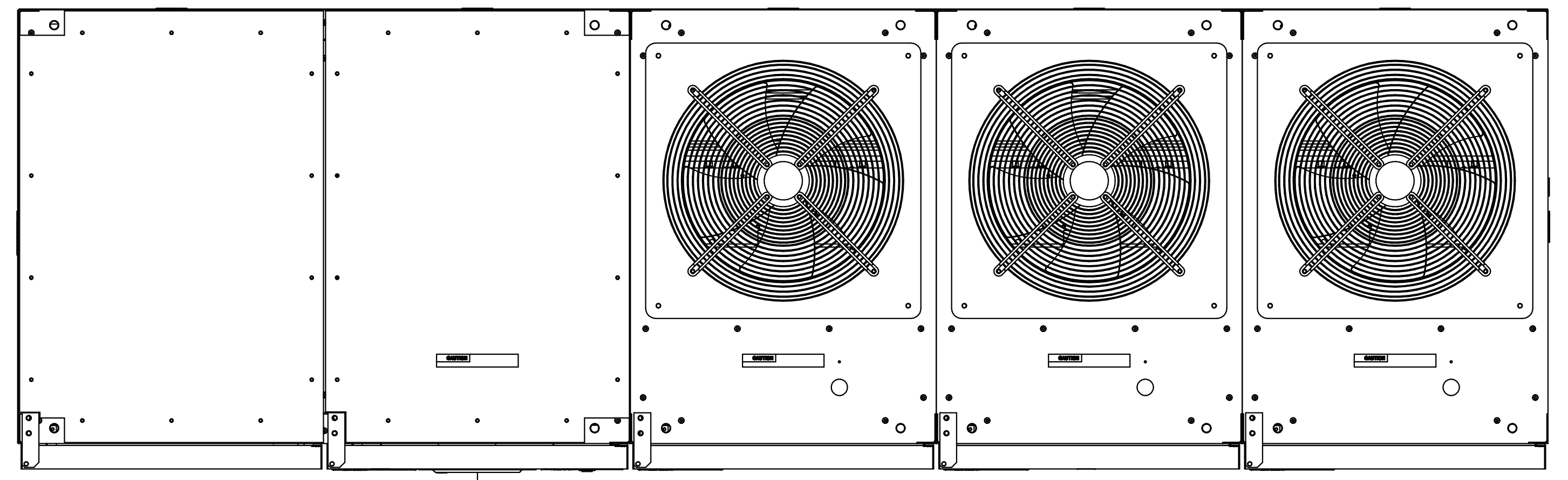

TOP VIEW
PANEL NOT SHOWN

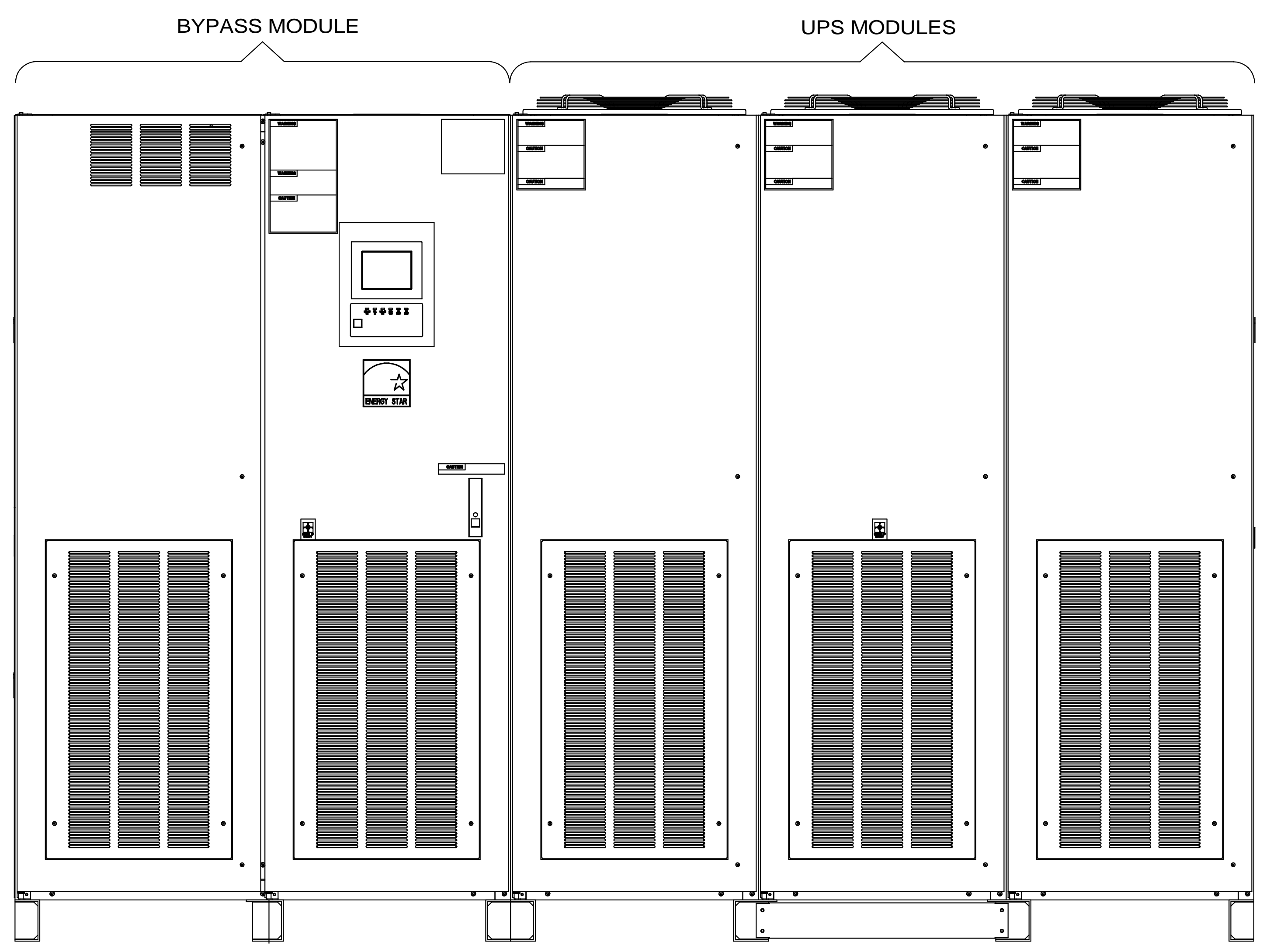

FRONT VIEW
PANEL NOT SHOWN

REVISIONS	DETAILS
4.	DELETED BUSS DETAILS
5.	ADDED REFERENCE FOR SHIPPING SPLIT ASSEMBLY DETAILS
6.	ADDED CENTER OF MASS DIMENSIONS TO SHEET 1 AND COVER SHEET
7.	HID PANELS ON SHEET 3 FOR DIMENSIONS
8.	ADDED CONDUIT ENTRY LOCATIONS

FABRICATION TOLERANCE		DIMENSIONS IN:		SCALE	DRAFTER	DATE
NOMINAL SIZE	TOLERANCE	IN	[MM]	(REP)	P. GUERRIERI	10/6/16
ANGLES	±0.01°					
HOLE TO MATERIAL EDGE	±0.01					
HOLE TO FORMED EDGE	±0.01					
HOLE TO HOLE	±0.005					
FORMED EDGE TO FORMED EDGE	±0.01					
FORMED EDGE TO WELDED EDGE < 48.0	±0.03					
FORMED EDGE TO WELDED EDGE > 48.0	±0.06					
PANEL DISTORTION OVER 48.0in	0.03 MAX					

PROPRIETARY		CORE [REFERENCE] DRAWING	
This document is the property of Mitsubishi Electric Power Products, Inc. and contains proprietary and confidential information which must not be duplicated, used or disclosed other than as expressly authorized by Mitsubishi Electric Power Products, Inc.			
APPROVED	N. RIEMER	DATE	10/10/16

		MITSUBISHI ELECTRIC	
TITLE			
9900C UPS MODULE			
DWG. NO.		SHEET 3 OF 6	
UD-100354		7	

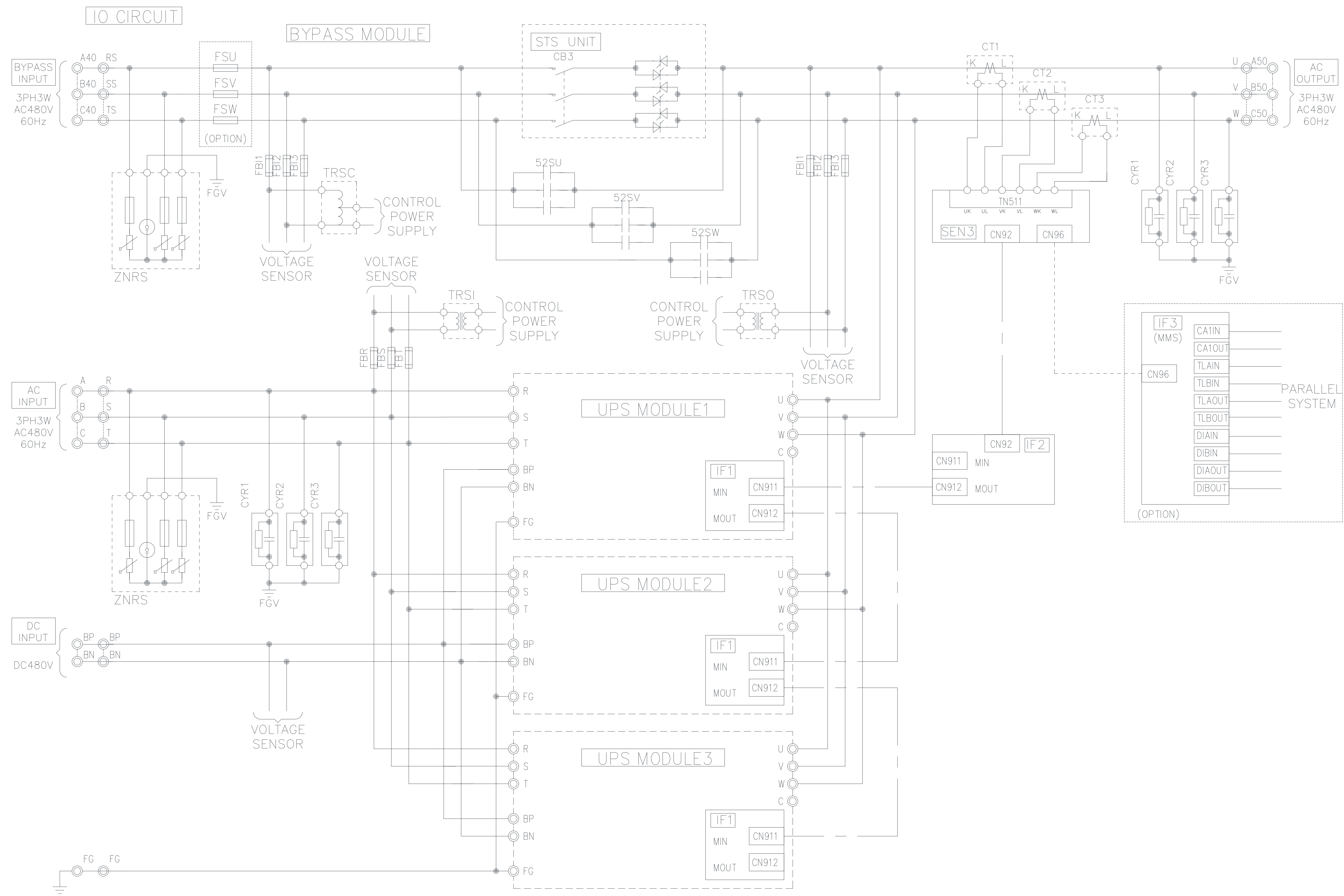

REVISIONS	DETAILS
4.	DELETED BUSS DETAILS
5.	ADDED REFERENCE FOR SHIPPING SPLIT ASSEMBLY DETAILS
6.	ADDED CENTER OF MASS DIMENSIONS TO SHEET 1 AND COVER SHEET
7.	HID PANELS ON SHEET 3 FOR DIMENSIONS
8.	ADDED CONDUIT ENTRY LOCATIONS

FABRICATION TOLERANCE	NOMINAL SIZE	TOLERANCE
ANGLES		±0.01°
HOLE TO MATERIAL EDGE		±0.01
HOLE TO FORMED EDGE		±0.01
HOLE TO HOLE		±0.005
FORMED EDGE TO FORMED EDGE		±0.01
FORMED EDGE TO WELDED EDGE < 48.0		±0.03
FORMED EDGE TO WELDED EDGE > 48.0		±0.06
PANEL DISTORTION OVER 48.0in		0.03 MAX

DIMENSIONS IN:	SCALE
IN [MM] (REP)	

DRAFTER P. GUERRIERI	DATE 10/6/16	MITSUBISHI ELECTRIC
APPROVED N. RIEMER	DATE 10/10/16	
CORE [REFERENCE] DRAWING		TITLE 9900C UPS MODULE DWG. NO. UD-100354 SHEET 4 OF 6 REV. 7

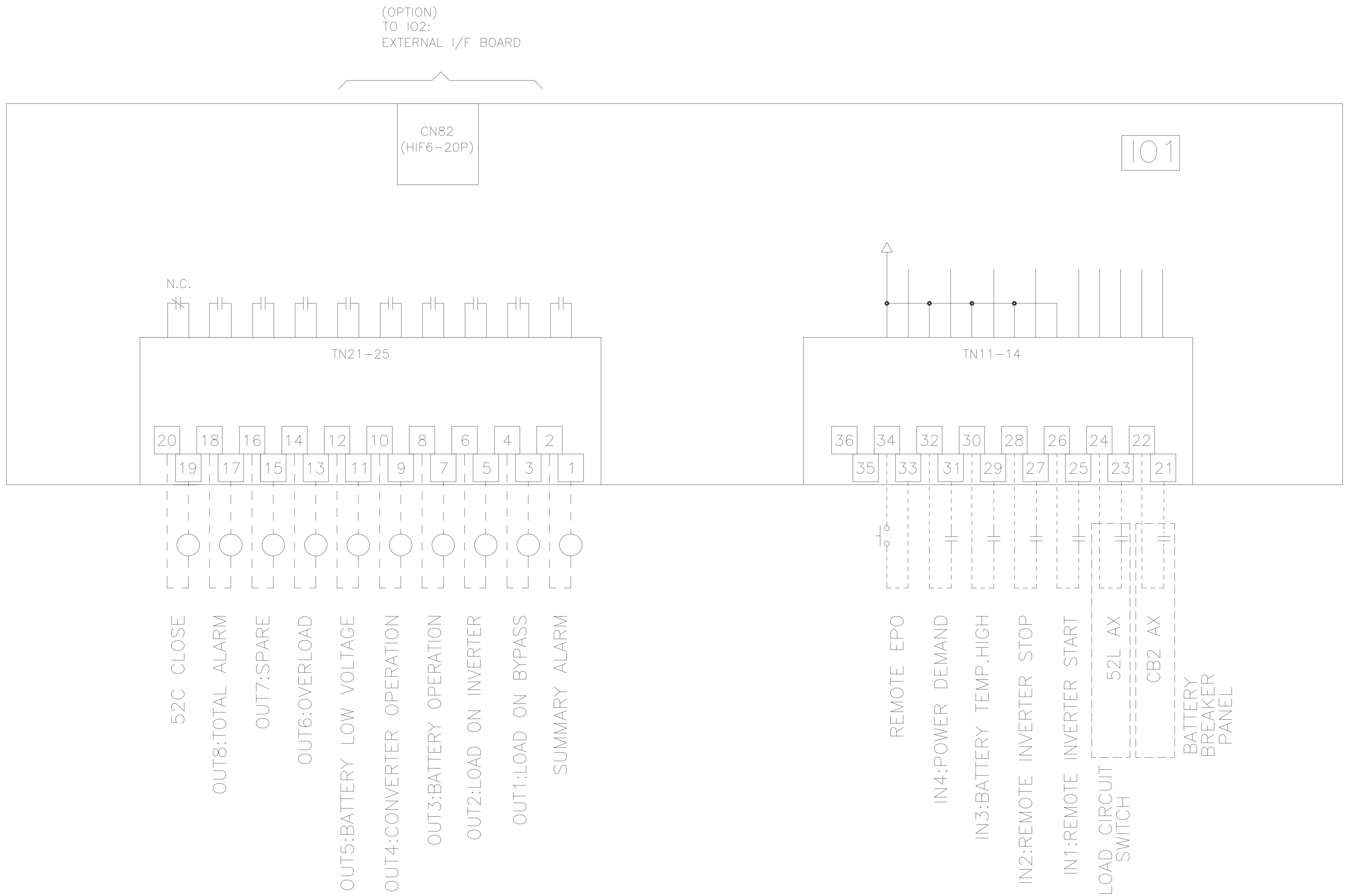

REVISIONS
4. DELETED BUSS DETAILS ADDED REFERENCE FOR SHIPPING SPLIT ASSEMBLY DETAILS P. GUERRIERI 10/6/2016
5. ADDED CENTER OF MASS DIMENSIONS TO SHEET 1 AND COVER SHEET Z.ZAJAC 11/21/17
6. HID PANELS ON SHEET 3 FOR DIMENSIONS J.MENDEZ 3/27/2018
7. ADDED CONDUIT ENTRY LOCATIONS Z.ZAJAC 8/14/2018

FABRICATION TOLERANCE	
NOMINAL SIZE	TOLERANCE
ANGLES	±0.01°
HOLE TO MATERIAL EDGE	±0.01
HOLE TO FORMED EDGE	±0.01
HOLE TO HOLE	±0.005
FORMED EDGE TO FORMED EDGE	±0.01
FORMED EDGE TO WELDED EDGE < 48.0	±0.03
FORMED EDGE TO WELDED EDGE > 48.0	±0.06
PANEL DISTORTION OVER 48.0in	0.03 MAX

DIMENSIONS IN:	SCALE
IN [MM] (REP)	

PROPRIETARY
This document is the property of Mitsubishi Electric Power Products, Inc. and contains proprietary and confidential information which must not be duplicated, used or disclosed other than as expressly authorized by Mitsubishi Electric Power Products, Inc.

DRAFTER	DATE
P. GUERRIERI	10/6/16
APPROVED	DATE
N. RIEMER	10/10/16

CORE [REFERENCE] DRAWING

MITSUBISHI ELECTRIC

TITLE
9900C UPS MODULE

DWG. NO. UD-100354 SHEET 5 OF 6 REV. 7

UPS MODULE (TYPICAL)

AC INPUT
3-PHASE 3-WIRE
AC480V 60Hz

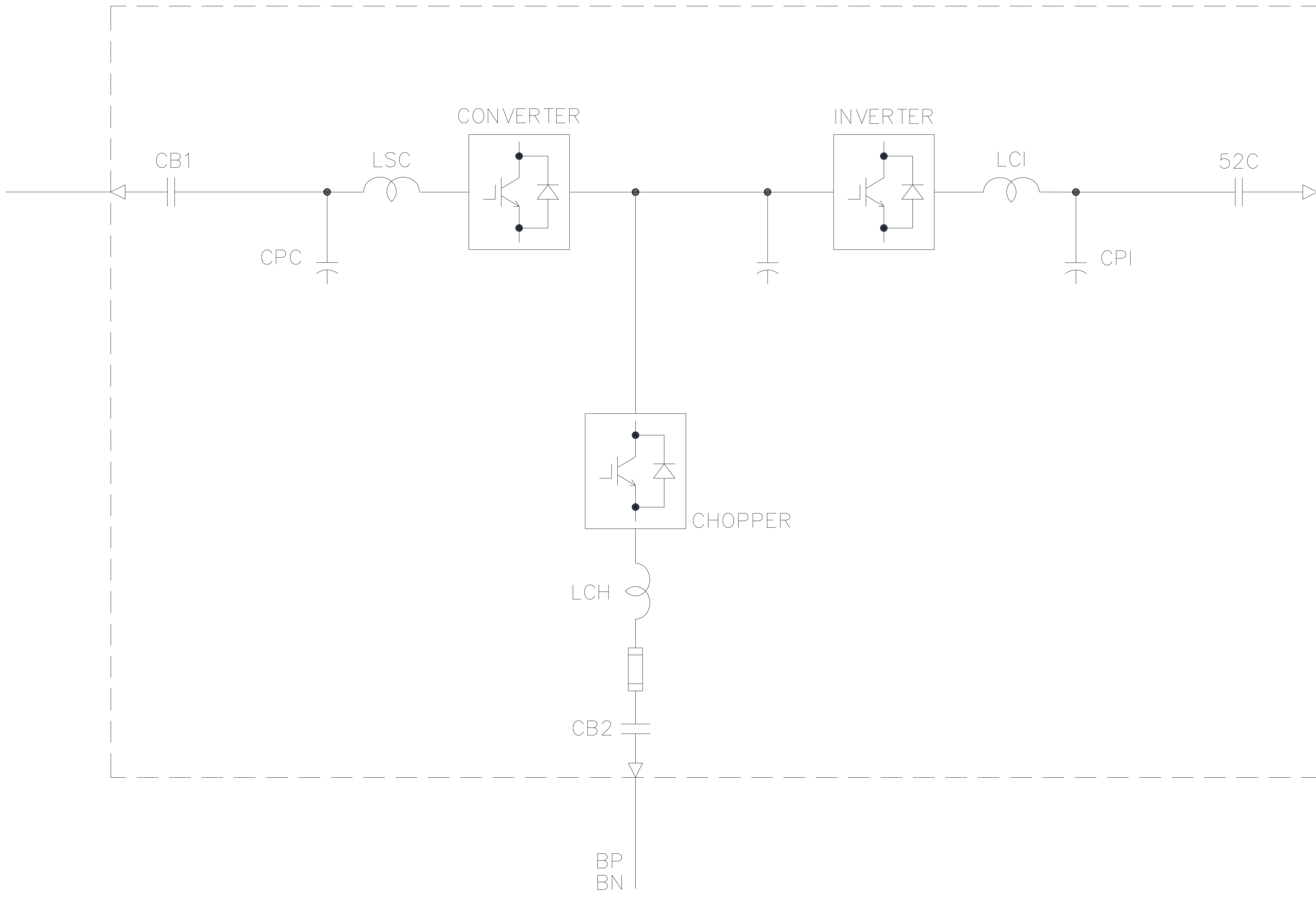

AC OUTPUT
3-PHASE 3-WIRE
AC480V 60Hz

REVISIONS
4. DELETED BUSS DETAILS ADDED REFERENCE FOR SHIPPING SPLIT ASSEMBLY DETAILS P. GUERRIERI 10/6/2016
5. ADDED CENTER OF MASS DIMENSIONS TO SHEET 1 AND COVER SHEET Z.ZAJAC 11/21/17
6. HID PANELS ON SHEET 3 FOR DIMENSIONS J.MENDEZ 3/27/2018
7. ADDED CONDUIT ENTRY LOCATIONS Z.ZAJAC 8/14/2018

FABRICATION TOLERANCE	
NOMINAL SIZE	TOLERANCE
ANGLES	±0.01°
HOLE TO MATERIAL EDGE	±0.01
HOLE TO FORMED EDGE	±0.01
HOLE TO HOLE	±0.005
FORMED EDGE TO FORMED EDGE	±0.01
FORMED EDGE TO WELDED EDGE < 48.0	±0.03
FORMED EDGE TO WELDED EDGE > 48.0	±0.06
PANEL DISTORTION OVER 48.0in	0.03 MAX

DIMENSIONS IN:	SCALE
IN [MM] (REP)	

PROPRIETARY
This document is the property of Mitsubishi Electric Power Products, Inc. and contains proprietary and confidential information which must not be duplicated, used or disclosed other than as expressly authorized by Mitsubishi Electric Power Products, Inc.

DRAFTER	DATE
P. GUERRIERI	10/6/16
APPROVED	DATE
N. RIEMER	10/10/16

CORE [REFERENCE] DRAWING

MITSUBISHI ELECTRIC

TITLE
9900C UPS MODULE

DWG. NO. UD-100354 SHEET 6 OF 6 REV. 7