

# **The Power of Green:**

## **Mitsubishi 9900A Series High Efficiency True On-Line Double Conversion Uninterruptible Power Supply (UPS)**

**Dean Richards** BEng (Hons) CEng MIET

Mitsubishi Electric Power Products Inc.: Manager of Sales and Engineering, UPS Division. USA \*

**Junichiro Onishi** BEc (Hons)

Mitsubishi Electric Corporation: Deputy General Manager, Overseas Marketing Department. Japan \*\*

**Abstract:** The following technical paper looks at the topology, design and breakthrough technology of the Mitsubishi 9900A Series UPS and the green orientated customer benefits associated with these systems. The trend of double conversion UPS technology is addressed leading to technical evaluations of Two-Level versus Three-Level converter topologies, with details of the associated control methods and switching patterns discussed. The custom Three Level Transistor Power Module (TLTPM) and integrated circuit utilized in the 9900A Series UPS is explained with the reliability of Three-Level circuit topology evaluated.

### **I. Introduction**

Uninterruptible Power Supply (UPS) Systems are one of the core components of mission critical infrastructure supporting all business sectors today. Of the different UPS topologies available, true on-line double conversion UPS Systems have emerged as the preferred topology because they offer reduced risk of critical load loss and therefore business loss due to power quality issues. On-line double conversion UPS Systems therefore offer the highest reliability and quality of continuous conditioned power to the critical load. With this reduced risk of critical load loss however, there was always a trade off in that overall system efficiency was lower compared to that of off-line or stand-by type UPS systems. This was due to increased switching loss of the semiconductor power devices in the conventional on-line double conversion circuit.

Today, the trend towards the “Green Outlook” and the “Greening of the Data Center” is already apparent; in which expectation for reduction of energy consumption in mission critical facilities through power usage effectiveness and cost of ownership is becoming one of the top priorities in the decision making process of equipment needs. Now it is not only a requirement to offer a highly technical, reliable and quality on-line UPS System that integrates seamlessly into the overall power infrastructure, but it must also be compact, lightweight and offer high operating efficiencies throughout the full load spectrum. To satisfy this total requirement, Mitsubishi has developed the 9900A Series UPS, our most innovative and efficient UPS System to date.

The following discusses the Mitsubishi 9900A Series UPS System and its breakthrough technology that results in green orientated customer benefits - The Power of Green:

### **II. Creating the trend of UPS technology**

Analyzing the trends in the technological advancement of semiconductor power devices and the emerging need for higher switching frequencies in power electronic applications such as UPS systems shows the emergence of the Insulated Gate Bipolar Transistor (IGBT) as the most advanced power device to offer superior UPS performance and reliability. In 1992, Mitsubishi Electric pioneered the use of full IGBT design in both converter and inverter sections of UPS systems. Today, IGBT devices are predominantly used in UPS inverter sections where the ability to switch on and off the device and instantaneously control it is essential. [It is important to highlight that using the IGBT device is important to benefit from the switching advantages that this device brings, but it is how the device is controlled is key to obtaining optimum performance and specification.] In UPS converter section's, various configurations including full IGBT, Diode/IGBT hybrid combination or Silicon Controlled Rectifier (SCR – also known as a thyristor) are available. The KVA capacity of the UPS Module typically determines the front end converter topology; with larger UPS Systems more likely to have IGBT/Diode front end design (for increased efficiency) or SCR rectifiers.

In larger capacity UPS Systems, three-phase 480V classification is typical (rather than 208V), aligning with the national distribution voltage that was originally designed for cost savings and to improve efficiencies in distribution due to reduced cable losses. With the green trend, there is increased interest in new design build of large data-centers utilizing 575/600V distribution classification for further improved cost savings and efficiencies. Medium voltage distribution in large

data-centers is also being discussed, and although today pure on-line UPS Systems in such voltage range do not exist (Some line interactive type medium voltage systems exist); it is an interesting discussion topic that leads perfectly into understanding the Three-Level converter and inverter topology of the 9900A Series UPS System.

Continuing the trend of breakthrough technology, Mitsubishi Electric introduces Three-Level Converter and Inverter topology to UPS Systems.

### III. Circuit Topology

The 9900A Series high efficiency true on-line double conversion UPS; associated single line diagram and operation flow are shown in Figure 1. The main circuit method consists of a transformer-less design concept and fully digital Pulse Width Modulation (PWM) controlled Three-Level IGBT Converter and Inverter Sections with a Bi Directional IGBT Chopper.

**Figure 1.** 9900A Series UPS System

Specification Overview:

- UPS Module Capacity: 80, 100, 150, 225KVA
- Output Power Factor: 0.9
- Input/Output: 3Ø, 3 Wire, 480V, 60Hz
- DC input voltage: 480V (Nominal)
- Single Module System (SMS) or Multi Module System (MMS) Application (Up to 4 UPS Modules in Parallel)



Single Line Diagram

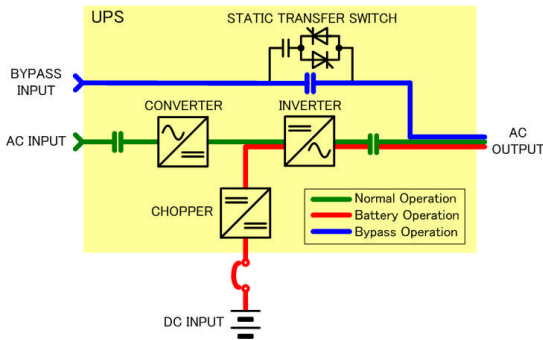

Note: Larger capacity 9900 Series UPS Modules are in development: 480V and 575/600V classification is being considered.

#### A. Three-Level Converter Topology

In power conversion applications such as UPS Systems, the term double conversion relates to the process of deconstructing or converting incoming AC Voltage to DC Voltage through a rectifier or what is known as the

converter section (input) and then reconstructing or converting the DC Voltage back to AC Voltage through what is called the inverter section (output). For simplifying the following description of Three-Level circuit topology, the power conversion circuits will be referenced to only as converter topology unless specifically stated.

The low-voltage power conversion market (up to 600V classification) is almost exclusively satisfied by the conventional Two-Level dc-voltage link converter topology. A conventional Two-Level converter circuit configuration is shown in Figure 2.

**Figure 2.** Conventional Two-Level converter topology

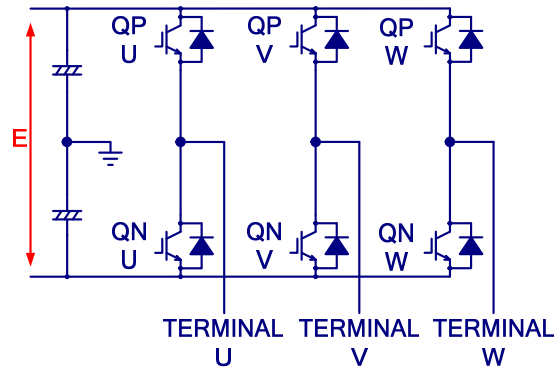

In contrast the medium-voltage power conversion market offers some diversity that includes Three-Level converter topology structures. A Three-Level converter circuit configuration is shown in Figure 3.

**Figure 3.** Three-Level converter topology

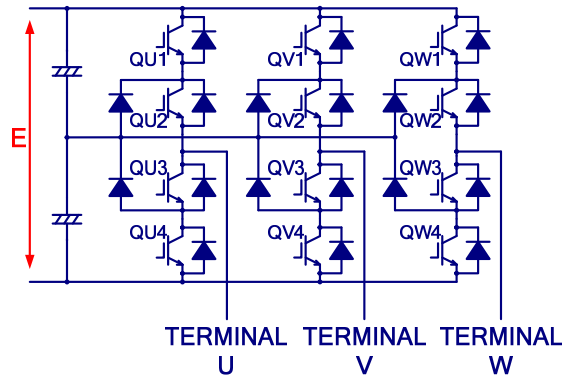

To understand this trend, it is important to note that with the emergence of the IGBT power device due to the need for higher switching frequencies in power electronic applications, the desire for substantially lower semiconductor switching losses and for smaller and lighter filter components has always been a factor. (This alone explains why many large capacity UPS Systems available today do not have full IGBT front end/converter sections; because of the associated cost, higher switching losses effecting overall efficiency and also because natural

commutation of the AC input sinusoidal voltage waveform allows automatic turn off of SCR and Diodes due to the inherent forward conduction characteristics of these devices.). IGBT switching loss and filter size and weight are therefore not new issues; however with the current need for more compact, lightweight and higher efficiency on-line UPS Systems, it became apparent that finding a solution to these issues were the main focus points to be addressed. In looking at the evolution of the medium-voltage power conversion market through large power applications and higher voltage classification, the technological solution to these issues was the use of Three-Level based converter topology in UPS Systems.

As can be seen, the conventional Two-Level converter circuit configuration consists of two IGBT power devices in each converter phase leg and current paths. For a Three-Level converter, the circuit configuration consists of four IGBT power devices in each converter phase leg and current paths. For UPS Systems with 480V classification, a Two-Level circuit typically corresponds to utilizing 1200V rated IGBT devices for the converter structure. A Three-Level circuit with the same terminal voltages can utilize 600V rated IGBT devices.

### B. Three-Level v Two-Level Topological Evaluation

Conduction losses are attributed to semiconductor devices being in the on-state and are a function of current and saturation voltage. Switching losses are distributed to the semiconductor devices involved in a commutation whenever a state transition takes place. Switching losses are a function of device voltage, current, switching frequency and junction temperature. At first glance, it would seem that by increasing the number of IGBT devices in the converter circuit for Three-Level topology; more switching loss would be associated. It would therefore appear that this is further enhancing the issue and problem we are trying to solve? When analyzing this more deeply however, the opposite is actually true. For a given dc-link voltage the power devices in a Three-Level converter require half the blocking voltage capabilities of that of a Two-Level converter, featuring superior conduction and switching characteristics for any given current. This lower voltage stress on the power semiconductors means that IGBT and diode devices with lower voltage ranges can be used without compromising performance and reliability. For example, 600V IGBT's feature on-state voltages that are approximately 10% lower than that of a 1200V IGBT at the same rated current and technology [Indicated by VCE in Graph 1.]. Similarly, the switching loss energies of a 600V IGBT with the same device technology and current are smaller by a factor of 5 [Indicated by Eon, Eoff in Graph 1.]. This implies that a series connection of two 600V IGBT devices in a converter phase leg current path features approximately half of the switching loss of one 1200V IGBT device while increasing the conduction loss by less than twice.

A converter topological evaluation for IGBT Switching and Conduction losses is shown in Graph 1. The following Mitsubishi 1200/600V IGBT (Two/Three-Level) power devices were compared:

- Mitsubishi CM200DU-24F 1200V IGBT (2-Level)
- Mitsubishi CM200DU-12F 600V IGBT (3-Level)

This evaluation assumes a comparable modulation technique, carrier and switching frequency and device technology for both converters. Approximate total switching and conduction losses applied to a UPS System are shown in Graph 2. Despite the higher conduction losses (two devices in current path) it can be seen that the Three-Level topology features lower total semiconductor losses than conventional Two-Level topology. The Three-Level topology therefore realizes an overall improvement of power conversion efficiency. Although this paper will not go into further detail, the modulation carrier control and switching frequency of the converter circuit also impacts the switching losses. Typically the higher the switching frequency the higher the associated losses (More switching can take place per half cycle). Therefore it can also be stated that lower losses are attributed to Three-Level converter topologies as the switching frequency increases. The switching frequency of the 9900A UPS converter circuits is 7.2KHz.

**Graph 1.** 1200/600V IGBT Switching and Conduction Losses

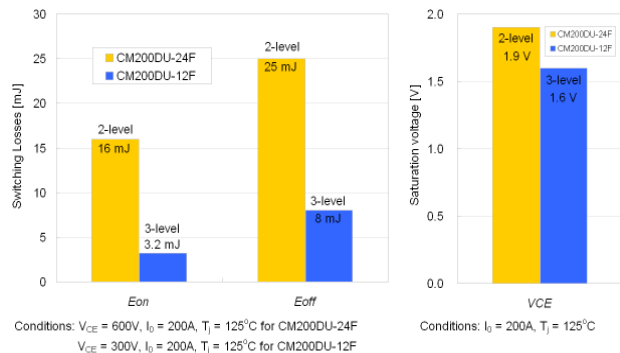

**Graph 2.** Total UPS System IGBT Losses (Approximate)

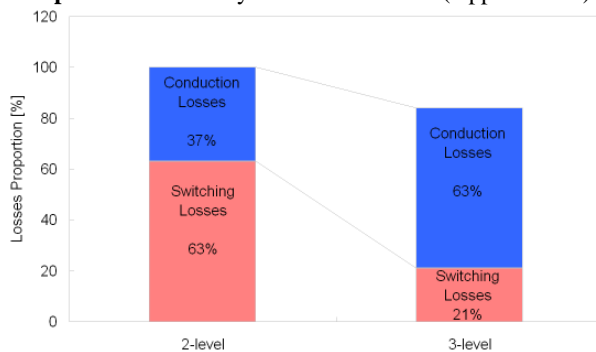

### C. Pulse Width Modulation Converter Control

With Pulse Width Modulation (PWM), the converter semiconductor power devices act as an array of switches and are turned on and off several times during each half cycle of voltage. The output voltage is therefore controlled by varying the width of pulses and durations that each device conducts. The following PWM explanation and circuit details will focus on the reconstruction of the UPS System output voltage waveform from conversion of the DC voltage link, and be specific to the UPS inverter section. The power device gate signals are determined by the PWM control circuit that compares a reference signal waveform to a carrier waveform and generates the device switching pattern through a Field Programmable Gate Array (FPGA) specific to load demand requirement and control feedback loop signals. Any UPS system must maintain sinusoidal output voltage regulation under all steady state and transient load conditions; therefore the dynamic performance of any UPS System largely depends on the control schemes applied. The 9900A UPS PWM Three-Level Converter Control philosophy utilizes full Direct Digital Control (DDC) with current minor loop and voltage major loop control per phase, that not only offers instantaneous output voltage and distortion control, but also inherent over current protection due to the limiter for the current minor loop reference. In addition simple and reliable control for parallel operation of inverters with instantaneous load current sharing and synchronization is achieved (Parallel UPS System application is covered in section VI: 9900A Series UPS Customer Benefits).

The control system utilizes a Digital Signal Processor (DSP) that controls the voltage regulation of the Converter, Inverter and Bi Directional Chopper power conversion circuits and therefore controls the UPS system. For the 9900A UPS, the DSP sampling frequency is 57.6KHz, therefore the control samples 960 times in one cycle of output voltage. Output voltage per phase is therefore controlled with high precision. Appendix 1 shows a typical test result for transient response and voltage regulation of a 9900A 225KVA UPS Module with 100% load applied to and from the system. This test was applied with no battery connected to the UPS Module, and confirms that using the IGBT device is important to benefit from the switching advantages that this device brings, but it is how the device is controlled is key to obtaining optimum UPS performance and specification.

The switching pattern and commutation of the IGBT devices therefore enable the synthesis of the converter output voltage waveform.

The waveform synthesis of a conventional Two-Level converter circuit is illustrated in Figure 4. The output voltage at each terminal varies between two levels:  $+E/2$  Volts and  $-E/2$  Volts. The voltage variation ( $dv/dt$ ) at the terminal is therefore equal to  $E$  Volts. The line-to-line voltage (for example, terminals U and V) has three voltage

levels ( $+E$ ,  $0$ ,  $-E$  Volts) and offers four possible switching pattern combinations as shown in Table. 1. The variable-width pulse train (line-to-line voltage) of a conventional Two-Level converter is shown in Figure 5. As mentioned, this converter description represents system output voltage reconstruction; therefore large output filter circuits will be required to suppress high frequency components and obtain a smooth sinusoidal output voltage waveform from the pulse train. [It is important to note that all UPS Systems require output filter circuits to create clean sinusoidal voltage waveforms.]

**Figure 4.** Two-Level Converter Waveform Synthesis

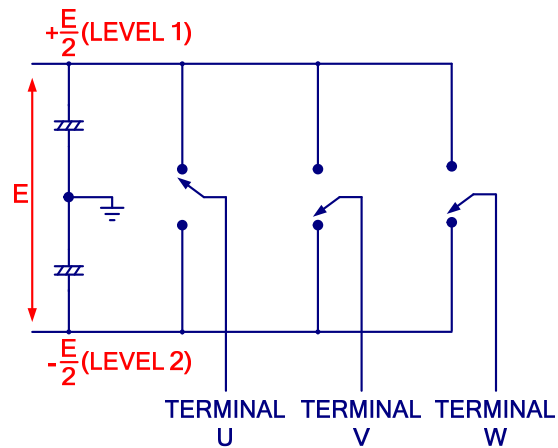

**Table 1.** Two-Level Converter Switching Patterns

Terminal U	Terminal V	Line-to-Line Voltage (U - V)
$+\frac{E}{2}$	$+\frac{E}{2}$	0
$+\frac{E}{2}$	$-\frac{E}{2}$	+ E
$-\frac{E}{2}$	$+\frac{E}{2}$	- E
$-\frac{E}{2}$	$-\frac{E}{2}$	0

**Figure 5.** Two-Level Converter Variable Width Pulse Train

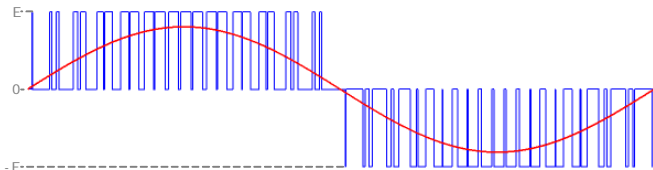

The waveform synthesis using Three-Level converter topology is shown in Figure 6. The output voltage at each terminal assumes one of three levels:  $+E/2$  Volts,  $0$ , and

$-E/2$  Volts. The voltage variation ( $dv/dt$ ) at the terminal is therefore equal to  $E/2$  Volts. Due to this additional voltage level, the number of switching pattern combinations increases. The line-to-line voltage (for example, terminals U and V) has five voltage levels ( $+E$ ,  $+E/2$ ,  $0$ ,  $-E/2$  and  $-E$  Volts) and offers nine possible switching pattern combinations as shown in Table 2. The variable-width pulse train (line-to-line voltage) of a Three-Level inverter is shown in Figure 7. Small filter circuits are required to obtain a sinusoidal output voltage waveform from the pulse train.

**Figure 6.** Three-Level Converter Waveform Synthesis

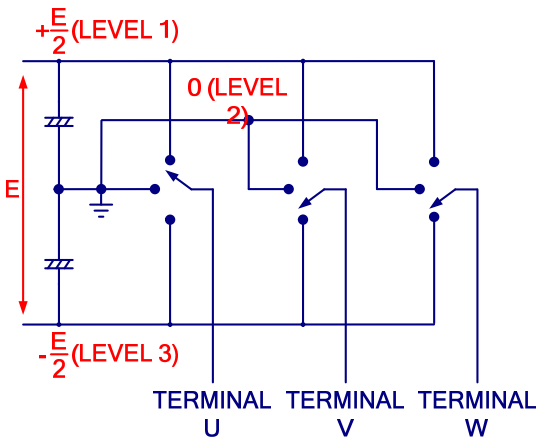

**Table 2.** Three-Level Converter Switching Patterns

Terminal U	Terminal V	Line-to-Line Voltage (U - V)
$+\frac{E}{2}$	$+\frac{E}{2}$	0
$+\frac{E}{2}$	0	$+\frac{E}{2}$
$+\frac{E}{2}$	$-\frac{E}{2}$	E
0	$+\frac{E}{2}$	$-\frac{E}{2}$
0	0	0
0	$-\frac{E}{2}$	$+\frac{E}{2}$
$-\frac{E}{2}$	$+\frac{E}{2}$	-E
$-\frac{E}{2}$	0	$-\frac{E}{2}$
$-\frac{E}{2}$	$-\frac{E}{2}$	0

**Figure 7.** Three-Level Converter Variable Width Pulse Train

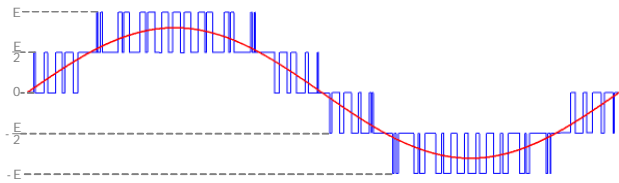

It can be seen that the output variable width pulse train of a Three-Level converter tracks the sinusoidal waveform much better than a conventional Two-Level converter circuit topology. This improvement in waveform synthesis means significant noise reduction (both acoustic noise and electromagnetic interference) due to the  $E/2$  Voltage variation ( $dv/dt$ ), and also that a smaller filter circuit can be used to obtain the required clean sinusoidal output voltage waveform required of a UPS System.

#### D. Passive Components

Passive components such as filters are a substantial contributor to weight, cost and losses in power converters. For Three-Level converter topology, reductions associated with the ac, dc,  $dv/dt$  and common mode filters can be seen. Continuing with the PWM control and waveform synthesis explanation; this paper will elaborate further in relation to the AC filter elements only:

The high frequency content in the terminal voltage of the Three-Level converter is substantially smaller due to the three level characteristic with an effective commutation voltage of 50% of that of the Two-Level converter ( $E/2$  versus  $E$  Voltage Variation ( $dv/dt$ )). The resulting harmonic currents are reduced by the same factor. Because the high frequency losses are a function of the square of the high frequency content of the current, the application of a Three-Level converter at a given inductance will result in substantially smaller losses. Alternatively, the ac filter inductance can be smaller/less heavy for a Three-Level topology to meet a given specification in terms of voltage or current harmonics. A comparison of converter circuit topologies with different filter reactor values (inductance) is shown in Figure 8. Simulated results demonstrate inverter current and associated harmonic spectrum at set switching frequency ( $f_s$ ) for the following configurations:

- Two-Level Inverter with 0.05 p.u. filter reactor
- Three-Level Inverter with 0.05 p.u. filter reactor
- Two-Level Inverter with 0.10 p.u. filter reactor

To equal the current ripple and harmonic spectrum performance seen in a Three-Level converter, a Two-Level topology requires a larger reactor in its filter circuit. Three-Level converter topology therefore allows more compact and lightweight design with lower associated losses versus conventional Two-Level configurations.

**Figure 8. Filter Reactor Comparison**

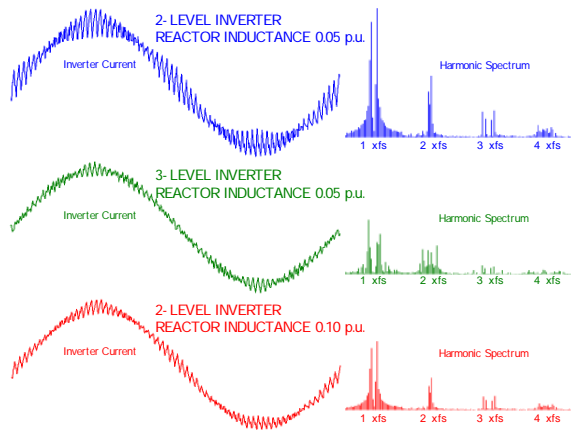

**IV. Three Level Transistor Power Module (TLTPM)**

In addition to the inherent benefits shown of Three-Level converter topology, high production volume justifies an integration of complete converter legs into one semiconductor power module. This optimization provides a compact design with further improvements in terms of component stress, noise and losses. A Three Level Transistor Power Module (TLTPM) and its circuit configuration, custom made for and utilized in the 9900A Series UPS Systems is shown in Figure 9.

**Figure 9. Three Level Transistor Power Module (TLTPM)**

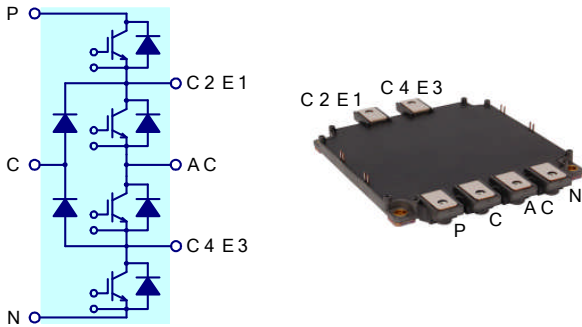

The most advanced IGBT are utilized in the TLTPM forming an integrated converter leg circuit that provides increased efficiency by reduction of semiconductor power losses, increased reliability through improved electrical and thermal characteristics and also reduces electromagnetic noise.

**V. Reliability Evaluation**

The Three-Level converter features a higher part count that would appear to compromise reliability. However, a closer analysis reveals other effects that balance the reliability numbers based on part count. The TLTPM helps with

reliability due to the integrated converter leg design and associated characteristic benefits, but unavoidable additional components are gate units, cabling and sensors. When analyzing failures in power electronics, the failure rate of IGBT semiconductors is very small compared to other components in the system. Cabling, control circuits and fan failures are the predominant causes of failure. All causes of failure however, are or can be positively influenced by adequate design choices. In particular, the lower losses of the Three-Level converter can reduce the ambient temperature of the gate units such that the number of failures is statistically equal to that of a Two-Level converter, despite doubling the number of units. Similarly, the capacitor life expectancy can be increased due to lower ripple current stress. The size and number of cooling fans, a component that contributes highly to total system failures can be reduced, in particular with high frequency converter applications. [It is important to note that by adding redundant fan configurations to UPS systems (which is typical in specifications), reliability will be compromised. In addition, normal cooling flow could be changed during fan failure conditions therefore mechanical damper circuits may also be necessary. From a design viewpoint, choosing a high quality fan with long life expectancy is a much more reliable solution for cooling of individual converter sections.] A complete reliability assessment is of course case dependent; however a Three-Level converter is not automatically inferior to a Two-Level converter when considering overall system reliability.

**VI. 9900A Series UPS Customer benefits**

The following discussion looks at the superior benefits and characteristics of the 9900A Series UPS System. For an evaluation basis, a comparison is made to the Mitsubishi 9800A Series UPS system, with this UPS Module incorporating Two-Level Converter topology and an output isolation transformer.

**A. Efficiency**

Typical AC to AC Efficiency data for Mitsubishi 9900A and 9800A 225KVA UPS Modules are shown in Graph 3.

**Graph 3. 225KVA UPS Module Efficiency Data**

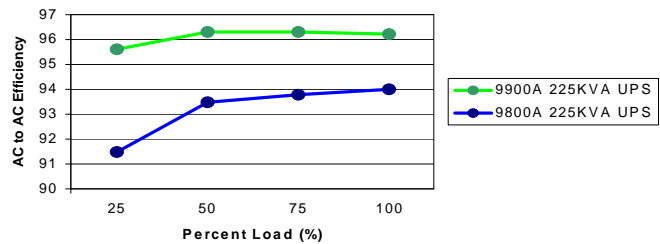

It can be seen that the 9800A UPS Module, which incorporates a Diode/IGBT Hybrid front end design for improved efficiency (due to reduced switching loss), offers efficiency characteristics up to 94%, with a drop off to

91.5% at lower load levels. This efficiency performance is already one of the highest for UPS Systems in the industry, especially in the larger power sizes that this series is available (Up to 750KVA UPS Modules and capable of parallel operation). It can be seen however; that the 9900A UPS Module offers more superior efficiency characteristics with up to 96.3% and a drop off to only 95.6% at the lower load level. This is a major consideration point; because typically UPS Modules are only loaded to between 30 and 50%, especially when considering parallel redundant applications. Efficiency values at lower load levels are therefore more important to users, allowing realistic calculations of overall losses and cost of ownership.

Typical efficiency curves drop off at lower load levels due to the constant losses associated with transformers and filter reactor components, and also because of variable semiconductor power device losses. Semiconductor losses relate to the magnitude of load current in relation to the device current rating and switching frequency influence. Conduction or on-state losses decline faster (quadratic dependency) than switching losses (linear dependency) with falling device current. For the 9900A Series UPS, AC reactor iron losses are comparatively small and IGBT switching losses are greatly reduced, therefore a flatter efficiency curve can be achieved.

Therefore in summary, the efficiency performance of the 9900A Series UPS System is the combination of a transformer-less design concept and Three-Level converter topology that allows reduced filter reactor losses and overall semiconductor losses. This not only provides the customer with significant UPS System operating savings, but it is also important to consider savings associated with reduced cooling needs (Higher efficiencies mean less heat rejection out of the top of the UPS Modules and therefore less air conditioning requirement). The 9900A Series UPS System has a significant “Efficiency Impact” on Data Center cost of ownership.

### B. Footprint and Weight

Dimensional and weight data for the Mitsubishi 9800A and 9900A Series UPS Systems are shown in Table 3.

It can be seen that the 9900A Series UPS Systems are considerably lighter and have smaller footprint compared to the 9800A Series UPS Systems. In summary this lightweight and small footprint design of the 9900A Series UPS System is a combination of a transformer-less design concept and a compact Three-Level converter topology (custom TLTPM integrated circuit) that requires much smaller filter components and cooling. The 9900A Series UPS Systems therefore take up less room and saves on precious data center floor space.

**Table 3.** Dimensional and Weight Data

9900A Series UPS		
KVA	Dimensions W x D x H (Inches)	Weight (LBS)
80	27.6 x 32.8 x 80.6	855
100	27.6 x 32.8 x 80.6	855
150	35.4 x 32.8 x 80.6	1160
225	35.4 x 32.8 x 80.6	1230
9800A Series UPS		
KVA	Dimensions W x D x H (Inches)	Weight (LBS)
80	N/A	N/A
100	43.3 x 29.8 x 79.7	2060
150	47.2 x 29.8 x 79.7	2580
225	55.1 x 29.8 x 79.7	3260

### C. Complete IGBT Integration

IGBT power devices are used in both the converter and inverter sections of the 9900A UPS Module. Combined with direct digital control methods, this offers superior UPS System input and output benefits:

#### UPS System Input:

With a full IGBT converter (rectifier) section, low input current harmonic distortion is realized without the need for additional filter circuits. Typical iTHD values are 3% at 100% load and 5% at 50% load. Another benefit of a full IGBT front end is that the input power factor can be controlled to unity. Both these items lead to excellent generator compatibility features: No over sizing of the generator is required to compensate for higher harmonic content and also no generator field excitation problems will occur because leading power factor conditions at light load levels are prevented. Many UPS Systems that utilize input filter circuits to reduce the input iTHD to acceptable levels have contactors that drop out the capacitive element of the filter circuit below certain load levels. This takes care of any generator compatibility issues specific to leading power factor, but could potentially lead to longer term problems that influence generator life. Such discussion topics related to high harmonic content and negative sequence currents will not be addressed in this paper. Another benefit of UPS Systems with full IGBT front end design is that resonance considerations between the generator and UPS system input filters are negligible.

Therefore, the 9900A Series UPS system further saves on precious floor space because additional input harmonic filter circuits are not required, and also allows smaller generator size considerations. This in turn adds to the overall green requirement, in that smaller power infrastructure equipment is realized.

## UPS System Output:

With an IGBT Inverter section and direct digital control methods, the output voltage waveform per phase can be instantaneously controlled with high precision. This fast inverter response allows excellent output performance and characteristics. Although 100% step loads are not typical for UPS Systems (50% step loads are commonly seen in parallel redundant multi module applications), it is a good specification criteria to evaluate UPS System output performance and control method technology. Typical transient voltage fluctuation for the 9900A UPS Module at 100% step load (without battery connected) is <2%. Typical test results are shown in Appendix 1.

### D. UPS Multi-Module System (UPS MMS) Application

The 9900A UPS Module can be utilized in Single Module System (SMS) or Multi Module System (MMS) applications satisfying any configuration requirement. Up to four UPS Modules of like KVA capacity can be paralleled together offering redundant or capacity system configurations. The Mitsubishi UPS MMS configuration is shown in Figure 10.

**Figure 10.** UPS MMS Configuration

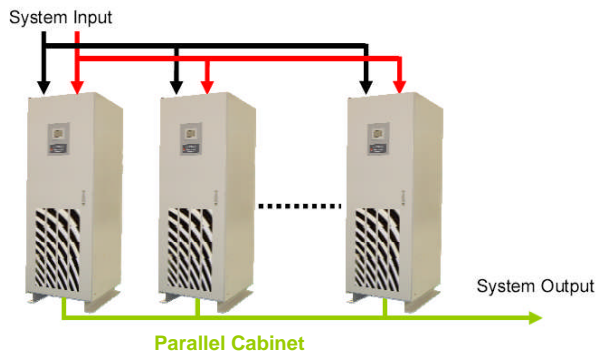

Mitsubishi UPS Multi Module Systems (UPS MMS) offer a different design, configuration concept and approach to Parallel Static UPS Systems. Instead of utilizing a common bypass static switch circuit and System Control Cabinet (SCC), each UPS Module in the parallel system incorporates its own internal bypass static switch circuitry and control and also its own internal parallel control circuitry. UPS Modules communicate using sensor-less cross current control technology ensuring proper system operation, load sharing and synchronization. A Parallel Cabinet is included to connect together all UPS outputs. This provides a parallel UPS system with complete system redundancy (including bypass circuit), high reliability and also with total flexibility. UPS Modules can easily be added to create or expand Multi Module Systems or even removed from multi module configurations and used in single module applications if the load demand permits.

## VIII. Conclusion

The transformer-less design concept and Three-Level IGBT converter topology of the 9900A Series UPS have been explored revealing the associated green customer benefits of such systems. It was shown that 9900A Series UPS Systems indeed meet the current market trend for highly technical, reliable and quality on-line UPS Systems that integrate seamlessly into the overall power infrastructure, but are also compact, lightweight and offer high operating efficiencies throughout the full load spectrum. The 9900A Series UPS development emphasizes today's mission critical infrastructure needs. The thirst for ever increasing demand means the overall cost of ownership of data centers are being squeezed. Efficiency is therefore becoming a serious consideration topic to ultimately obtain more economical operation practices and quicker return on investment. Although typically overshadowed by monetary savings, sustainability and overall environmental impact should also be a driving factor for the choice of new infrastructure equipment, being designed with reduced raw material requirements. This paper "The Power of Green" relates to the current market needs and proposes a UPS system solution to satisfy this need.

[Authors note: Five International patents have been applied for the 9900A Series UPS]

### Authors:

\* **Dean Richards** received a first class honors degree in Electrical and Electronic Engineering from Swansea University, United Kingdom in 1995. Starting his career with British Steel Plc. in 1988, Dean progressed from an electrical apprentice to a Department Electrical Engineer before joining Mitsubishi Electric Corporation in 1997. Through 2001, Dean worked as an electrical engineer in the power electronics department and UPS section of Mitsubishi, located in Kobe Japan. Through 2006, various positions were undertaken in the engineering and marketing departments of Mitsubishi headquarters, located in Tokyo. Dean joined Mitsubishi Electric Power Products Inc. in 2006, and is the Manager of Sales and Engineering of the UPS Division located in Warrendale PA.

\*\* **Junichiro Onishi** received a first class honors degree in Economics from CHUO University, Japan in 1985. Joining Mitsubishi Electric Corporation in 1986, initially working in Kobe, Junichiro has held various positions throughout his career. He is currently the Deputy General Manager, Overseas Marketing Department of the Public Utilities Group in Mitsubishi headquarters, located in Tokyo.



**References:**

- 1. ALQ-C10085: Mitsubishi UPS Inverter Control:  
Author: Dean Richards
- 2. ALN-H0824: Mitsubishi IGBT:  
Authors: Dean Richards, Takahiro Kawahara
- 3. ALQ-C10094: 9800A UPS Converter  
Author: Dean Richards
- 4. Comparison of Three-Level Converters versus Two Level Converters for Low Voltage Drives  
Authors: Ralph Teichmann, Steffen Bernet
- 5. IGBT Data Sheets: CM200DU24F, CM200DU12F available at [www.mitsubishichips.com](http://www.mitsubishichips.com)
- 6. A survey of the Reliability with an analysis of faults on variable frequency drives  
Authors: O. Thorsen, M. Dalva

**APPENDIX 1. 9900A 225KVA UPS Module Output Voltage Transient Response and regulation for 100% Step Load Application (No Battery Connected)**

